

## Rockfon® Concealed Acoustical Ceiling Systems (CDX) for Seismic Category D, E, F Applications

### Installation Guide



Project – Lions Park Søllerød in Nærum, Denmark  
Products – Rockfon Sonar® CDX

### Acoustic Ceiling Tile

- Ideal solution for various design applications, including Office, Classroom, Corridor, and Reception areas
- A complete acoustic solution, featuring a 0.90 NRC
- Easy and quick installation



## Fully Concealed Rockfon CDX

Rockfon fully concealed CDX panels have been shake table tested under the following conditions; the installation details described below are the minimum acceptable installation method. All installation details not shown are per ASTM C636 and ASTM E580, and are subject to additional requirements governed by local building codes and regulations. Consult with local engineer of record or authority having jurisdiction to verify compliance for your project.

CDX concealed tiles have two supporting X1 and two non-supporting X2 edges. In all rectangular panels, the X1 supporting edge is always the longer edge.

For more installation details, reference the Rockfon installation guide for CDX/SCD.

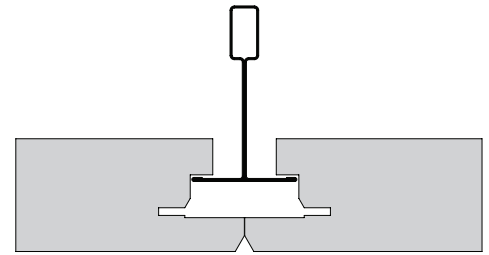

CDX edge detail

### X1: Supporting Edge

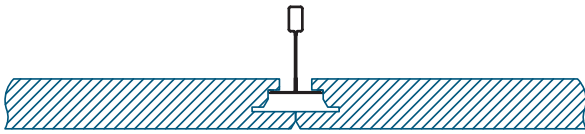

### X2: Non-supporting Edge

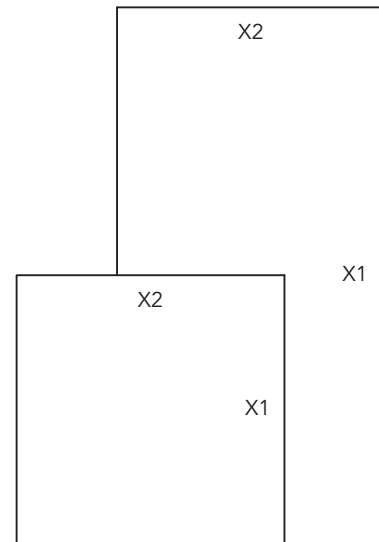
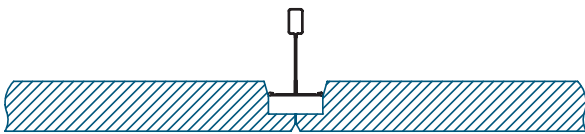

## Field Installation

### Grid

The field grid is installed following the practices outlined in ASTM C636 and ASTM E580 and must conform to all local building codes and standards. This includes the requirement of seismic restraint using downposts as prescribed in the standard.

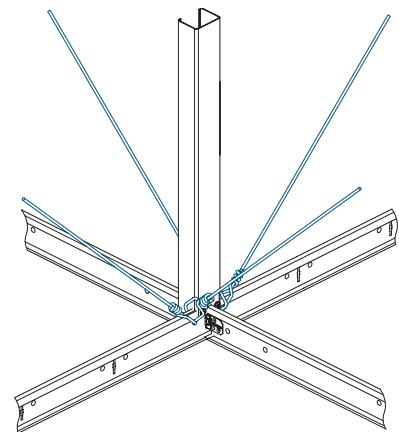

Downpost installation detail

# Grid Layouts

For standard 2' x 2' and 2' x 4' installations, the main runners are installed on traditional 48" centers. For plank panel installations, the main runners are spaced at the distance of the long panel edge; reference the below layouts as a guide. Install downposts at grid intersections at 12' centers maximum.

## 2' x 2' and 2' x 4' Layouts

### Grid

- 200: Main Runners
- 1210: 4' Cross Tees
- 1202: 2' Cross Tee
- Hanger Wires

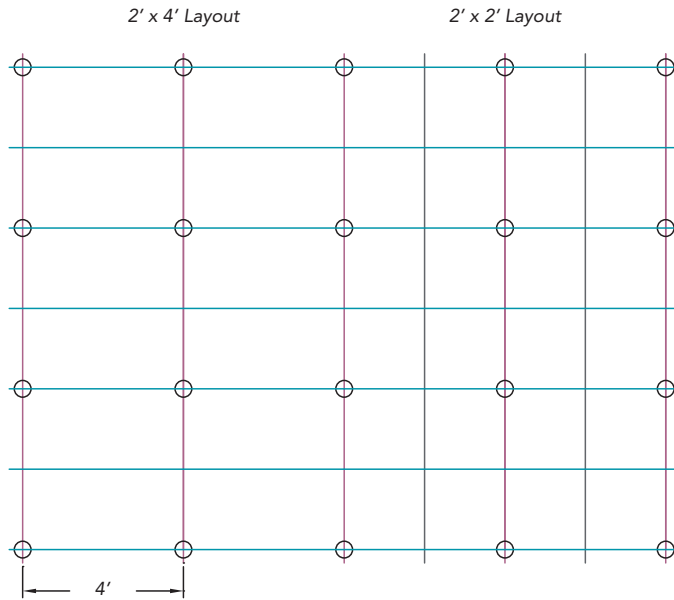

### Grid

- 200: Main Runners
- Cross Tees:
  - 1278: 8' Cross Tee
  - 1236: 6' Cross Tee
  - 1296: 5' Cross Tee
- 824.00H Spacer Bar
- Hanger Wires

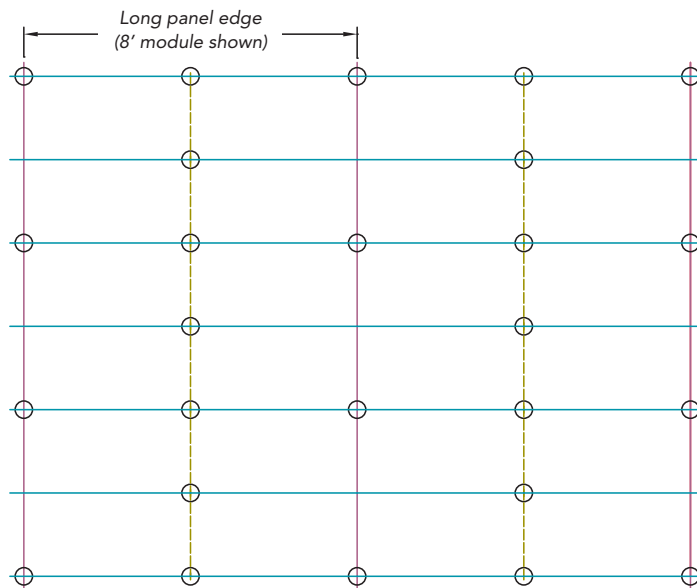

## Field Panels

The full field panels are installed from below and require 490 concealed hold down clips in seismic D, E, and F installations. These 490 concealed hold down clips do not limit accessibility of the system. Always install the 490 concealed hold down clips on cross tees and on the X1 supporting edge. Installing these on the X2 non-supporting edge will create panel lipping and poor aesthetics on the finished ceiling. The 490 concealed hold down clips install quickly and easily by pushing the clips over the bulb of the grid.

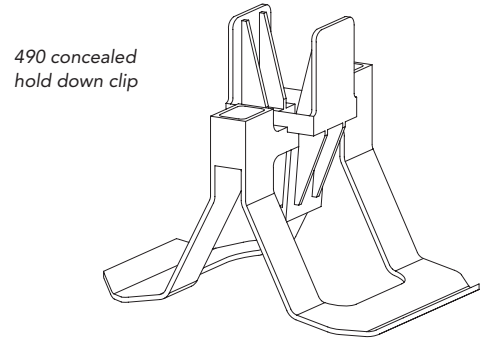
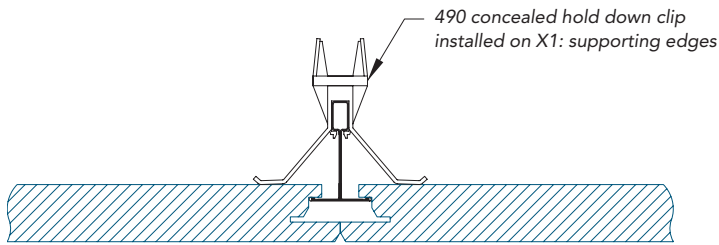

### Hold Down Requirements

Panel size	Hold downs X1 Edge	Location
2' x 2'	1	Centered on X1 edge
2' x 4'	1	Centered on X1 edge
20" x 5'	2	1' from X2 edge
2' x 5'	2	1' from X2 edge
2' x 6'	2	18" from X2 edge
2' x 8'	2	2' from X2 edge

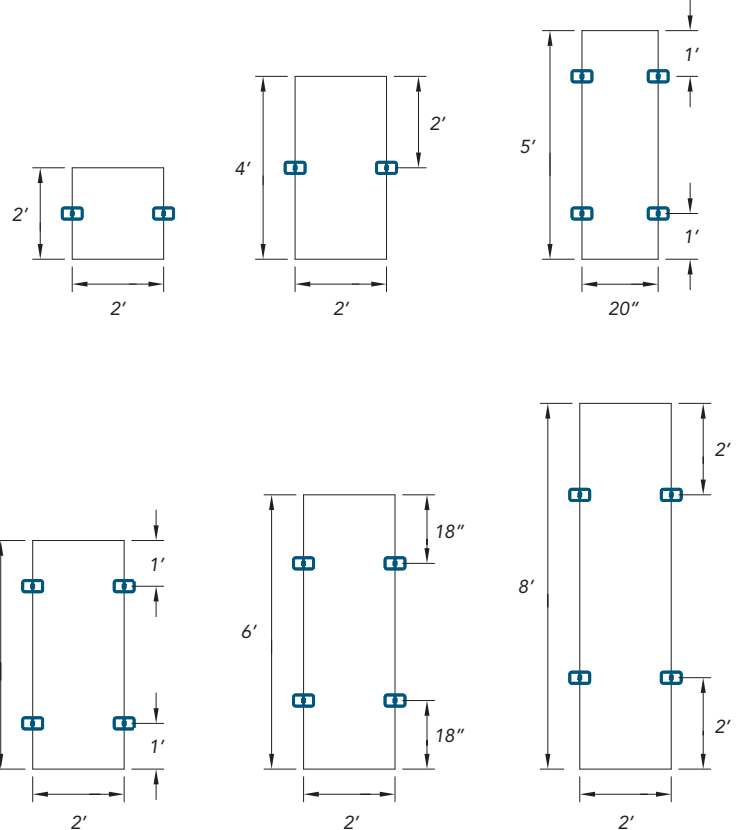

## Perimeter Details

In all seismic design categories, special attention must be given to the perimeters. Per ASTM E580, two adjacent walls are to be fixed or anchored and the remaining two adjacent walls are floating with the suspension components cut 3/4" short of the wall to allow movement of the system. All grid components must have a suspension wire within 8" of the wall as described in the code.

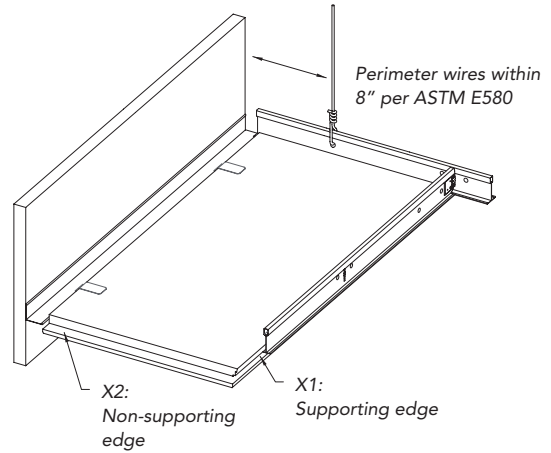

## Tested Code Alternatives

The use of Rockfon 472 CDX/SCD border clips in conjunction with seismically accepted code alternative perimeter conditions have been shake table tested for use with the 1496 seismic perimeter clip. The 1420 wall angle is an industry standard wall enclosure. This option will create a reveal around the perimeter of the room. If it is desired to have a flush finished ceiling, the 1454 concealed boxed wall angle sets the grid height to flush out the face of the tile. In both options the perimeter tiles are straight cut to fit snugly against the wall angle. For the 1420 wall angle the cut edge may require in-field finishing. Rockfon (RFN940 or RFN940Q) paint is available for finishing the cut edge.

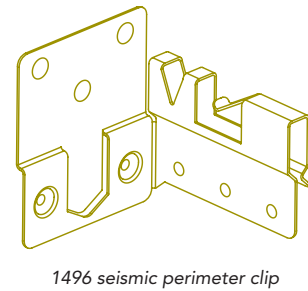

## 1420 Wall Angle with 1496 Seismic Perimeter Clip

Free wall details shown, suspension cut back 3/4" as described in ASTM E580. Attach the 1496 seismic perimeter clip to the wall using two #8 - 9/16" metal lath screws through the two lower holes of the clip into the wall angle. The grid on the fixed wall can be cut tight to the wall and attached to the 1420 wall angle with a 1/8" aluminum pop rivet with a steel mandrel. The 472 CDX/SCD border clips are only required when recreating a supporting edge.

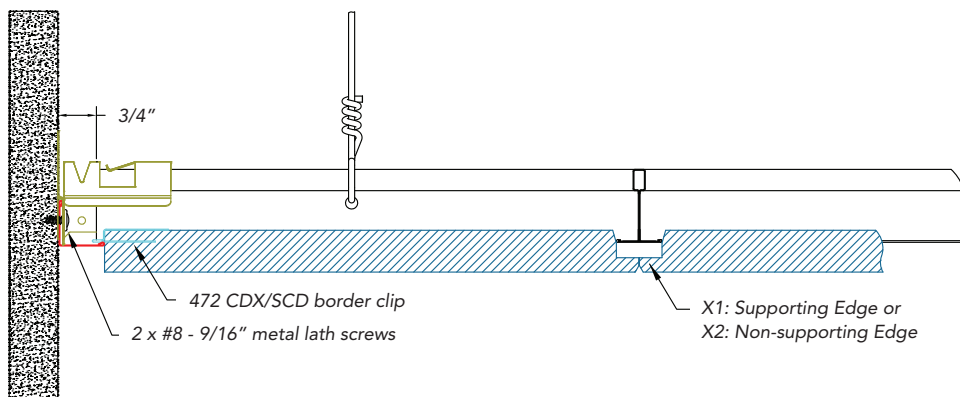

## 1454 Concealed Boxed Wall Angle with 1496 Seismic Perimeter Clip

Free wall details are shown, with suspension cut back 3/4" as described in ASTM E580. Attach the 1496 seismic perimeter clip to the wall using two #8 - 9/16" metal lath screws through the two lower holes of the clip into the wall angle. The grid on the fixed wall can be cut tight to the wall and attached to the 1454 concealed boxed wall angle with 1496 seismic perimeter clips. Secure the 1496 seismic perimeter clip to the 1454 concealed boxed wall angle as described above; secure to the grid using one #7 - 7/16" sharp point screw minimum. The 472 CDX/SCD border clips are only required when recreating a supporting edge.

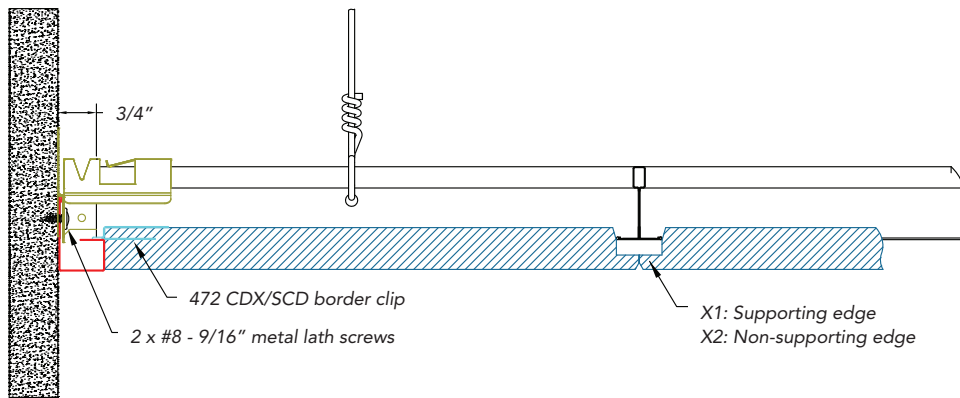

## 472 CDX/SCD Border Clip

All panel sizes require the use of the 472 CDX/SCD border clip spaced at 12" on center with the clip near the edge of the tiles being positioned 4" from the panel edge.

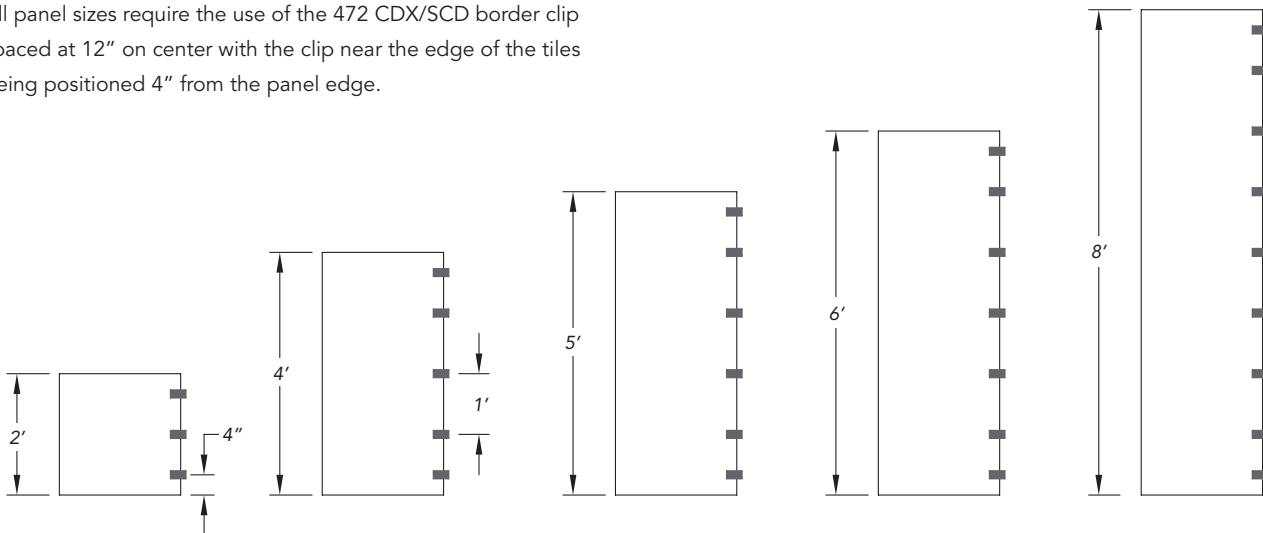

The 472 CDX/SCD border clip is designed with an upper blunt edge and a lower pointed portion for piercing the edge of the panels. The upper portion is longer than the piercing surface. Align the upper flat portion on the back surface of the panel and push the clip into the fibers of the panel.

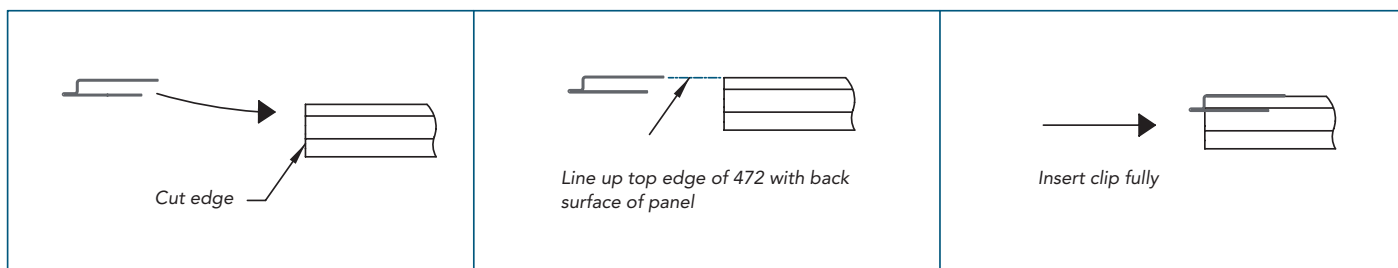
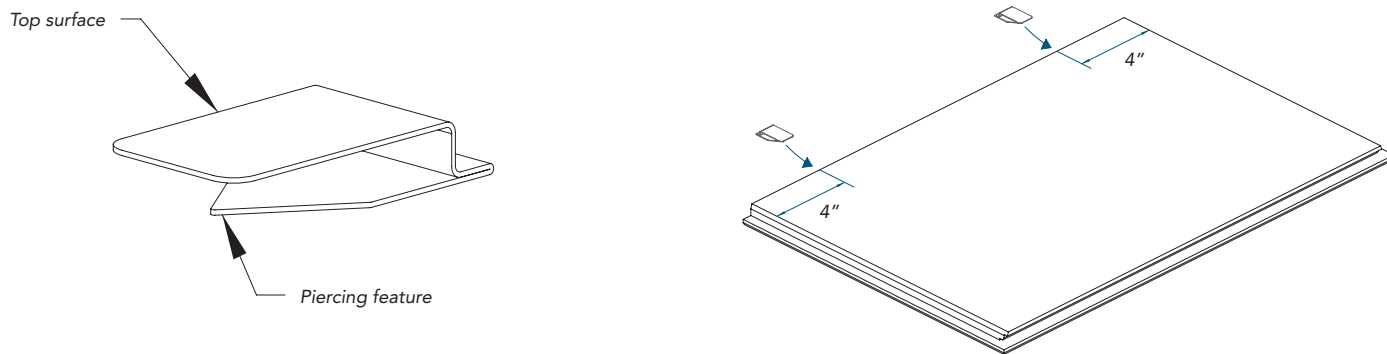

## Have Questions?

Contact the Rockfon Technical Services Team by calling **800-323-7164** and we can provide assistance on your project.

Rockfon® is a registered trademark  
of the ROCKWOOL Group.

2018 | Subject to alterations in range and product technology without prior notice. Rockfon accepts no responsibility for printing errors.  
© ROCKWOOL International A/S 2018. All rights reserved. ® denotes a trademark that is registered in the United States of America.



**Rockfon**  
4849 S. Austin Ave.  
Chicago, IL 60638 USA

Tel. +1-800-323-7164  
Fax. +1-800-222-3744  
[www.rockfon.com](http://www.rockfon.com)