



Acoustic Hub system

- The platform brings multipurpose flexibility to your interiors by creating breakout spaces where people can think, work or talk in peace
- The soft island shapes can be enhanced with a felt frame cover, mood lighting and curtains to create calm or cosy areas where people can work productively without disturbance
- Rockfon® Hub™ is delivered as a complete kit contributing to easy and hassle-free installation

Description

Rockfon Hub is an innovative and acoustic island platform for creating zones and space-in-space designs. Rockfon Hub is available in 4 standard dimensions and consists of a two-grooved black anodized frame – possible to be customized with felt - and concealed X-edge tiles in multiple colours. Curtains can be added as well. The platform is suspended to the soffit using subtle looking wire sets.

Restrictions

Due to the risk of corrosion, Rockfon Hub should not be used in swimming pools or outdoor environments. Furthermore, Rockfon Hub should not be used in areas subjected to wind load and drafts.

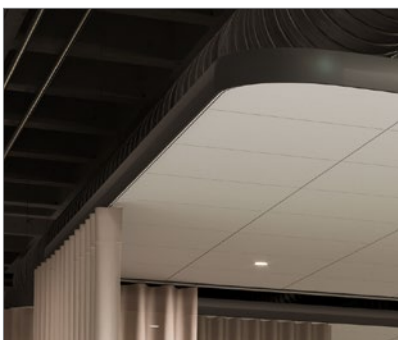

Matte black anodized finish.

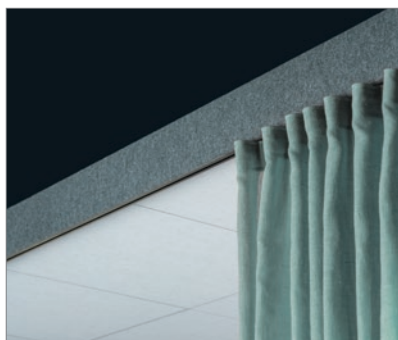

Option to customize frame with different colours of felt.

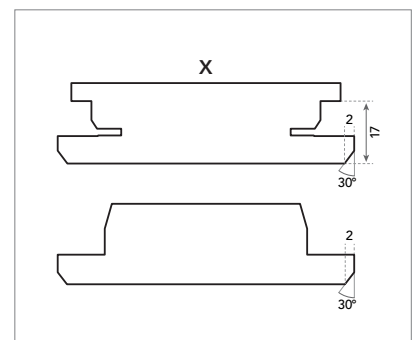

Concealed grid system with the symmetric X-edge ensuring fast mounting in both directions.

System components and consumption guide

| Tile | | Profiles | | | | | | | | Suspension | | Chicago Metallic T24 Click 2890 | | |
|-------------------------------|--------|------------------------|-------|-------|-------|----------------------|-----------------|-------|-------|------------|-------------------|---------------------------------|---------------------------------|-------------------------|
| | | 1 | | | | 2 | 3 | | | | 4 | 5 | 6 | 7 |
| X-edge (Rockfon Color-all) | | Frame Profile Straight | | | | Frame Profile Corner | Carrier Profile | | | | Vertical Wire Set | Bracing Wire Set | Main runner T24 Click/Hook 3600 | Cross tee T24 Click 600 |
| | | a | b | c | d | | a | b | c | d | | | | |
| 600 x 600 | | 1800 | 2400 | 3000 | 3600 | | 868 | 1200 | 2976 | 3576 | | | | |
| Hub dimensions (mm) | | Consumption/Unit | | | | | | | | | | | | |
| 3000 x 4800 | 40 pcs | 2 pcs | - | - | 2 pcs | 4 pcs | 4 pcs | - | 4 pcs | - | 16 pcs | 8 pcs | 8 pcs | 6 pcs |
| 3600 x 4200 | 42 pcs | - | 2 pcs | 2 pcs | - | 4 pcs | 4 pcs | - | - | 3 pcs | 13 pcs | 8 pcs | 10 pcs | 8 pcs |
| 4800 x 4800 | 64 pcs | - | - | - | 4 pcs | 4 pcs | 6 pcs | 4 pcs | - | 4 pcs | 18 pcs | 8 pcs | 14 pcs | 12 pcs |
| 4800 x 7200 | 96 pcs | - | - | 4 pcs | 2 pcs | 4 pcs | 6 pcs | 6 pcs | - | 6 pcs | 24 pcs | 8 pcs | 21 pcs | 18 pcs |

| | | Accessories | | | | | | | | | |
|-----------------|--|------------------------|----------------|-------------------|-------------------|-------------------|----------------------|------------------|-------------|-----------|------------------|
| | | 8 | 9 | 10 | 11 | 12 | 13 | 14 | 15 | 16 | 17 |
| | | Frame Profile Coupling | Coupling Screw | Profile Connector | Inter Connector R | Intersection Clip | M6 Hammer Head Screw | Cutting Template | Felt Cover* | Curtain** | Curtain Rollers* |
| Dimensions (mm) | | Consumption/Unit | | | | | | | | | |
| 3000 x 4800 | | 16 pcs | 32 pcs | 8 pcs | 32 pcs | 24 pcs | 24 pcs | 1 pcs | optional | optional | optional |
| 3600 x 4200 | | 16 pcs | 32 pcs | 8 pcs | 28 pcs | 25 pcs | 25 pcs | 1 pcs | optional | optional | optional |
| 4800 x 4800 | | 16 pcs | 32 pcs | 16 pcs | 40 pcs | 42 pcs | 42 pcs | 1 pcs | optional | optional | optional |
| 4800 x 7200 | | 20 pcs | 40 pcs | 22 pcs | 48 pcs | 56 pcs | 56 pcs | 1 pcs | optional | optional | optional |

* supplied by Rockfon

** not supplied by Rockfon. Please contact Rockfon for more details.

Tile - X Edge

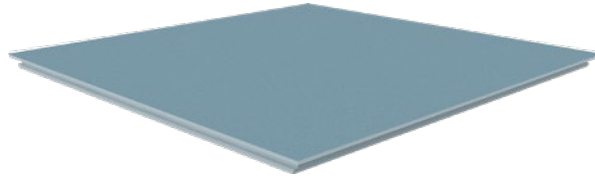

Profiles

1. Frame Profile Straight



2. Frame Profile Corner



3. Carrier Profile

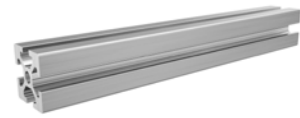

Suspension

4. Vertical Wire Set
(l=3500 mm / Ø2.00 mm)



5. Bracing Wire Set
(l=3500 mm / Ø2.00 mm)



Chicago Metallic T24 Click 2890

6. Main runner T24 Click/Hook 3600



7. Cross tee T24 Click 600



Accessories

8. Frame Profile Coupling



9. Coupling Screw



10. Profile Connector



11. Inter Connector R



12. Intersection Clip



13. M6 Hammer Head Screw



14. Cutting Template



15. Felt Cover*

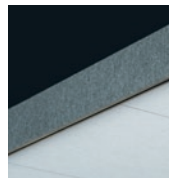

16. Curtain**

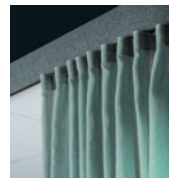

17. Curtain Rollers*



Tool List

| Tools | Drill machine | Screw machine | Ruler | Allen key | Wrench | Metal shears | Laser | Utility knife | Felt tool (optional) | Gloves | Level |
|-------|---------------|---------------|-------|-----------|--------------|--------------|-------|---------------|----------------------|--------|-------|
| | | | | | | | | | | | |
| Size | - | - | - | 2,5 / 4 | 10 / 13 / 14 | - | - | - | - | - | - |

* supplied by Rockfon

** not supplied by Rockfon. Please contact Rockfon for more details.

Compatible Tiles Overview

Only Rockfon X-edge tiles can be used for Rockfon Hub.

| | | Dimensions (mm) |
|---------------------|----------------|-----------------|
| Tiles | Thickness (mm) | 600 x 600 |
| Rockfon® Blanka™ | 22 | • |
| Rockfon Color-all®* | 22 | • |

*For Rockfon Color-all we pre-selected several colours to match with the felt.

System suspension height (mm)

Tiles and grid mounted in Rockfon Hub are fully demountable.

The suspension height is defined as the distance from the bottom of the frame to the soffit.

| | D = Distance between soffit and bottom of the frame |
|------|-----------------------------------------------------|
| mm | |
| Min. | 250 |
| Max. | 1500 |

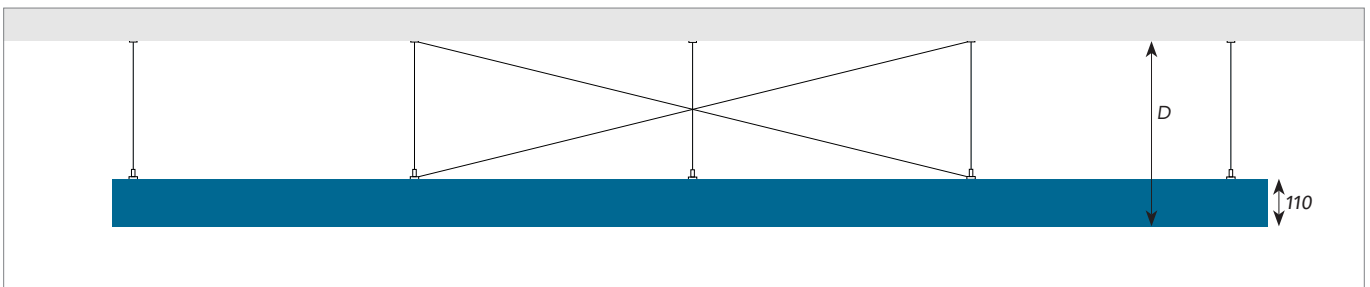

Installation

Ensure that the correct mounting fixings for the ceiling substrate are available. The mounting fixings must not be plastic. A break load of 200kg/suspension point is strongly recommended.

The installation of Rockfon Hub can be done at waist level (see step 2). If the platform is assembled on the floor (not recommended),

a work blanket should be used to prevent the Frame Profiles from being damaged.

For off-floor assembly (recommended), consider the ideal workheight for the installer. After assembly, Rockfon Hub can be lifted and leveled with a laser.



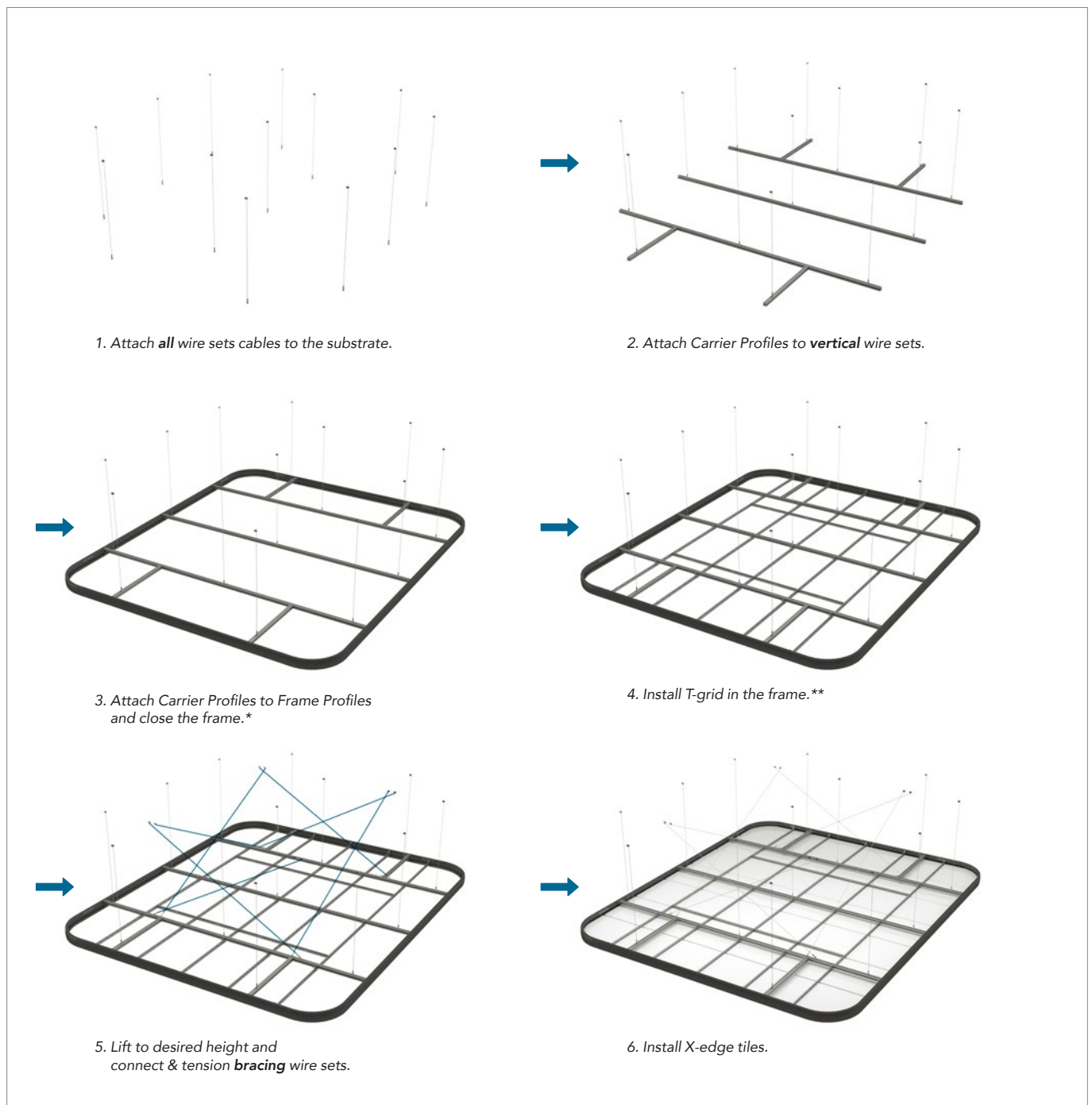

Quick installation for mounting Rockfon Hub



* If using curtains, insert curtain rollers before closing the frame

** If using felt cover, insert here (before lifting)

1. 3000 x 4800

-  Frame Profile
-  Carrier Profile
-  Vertical Wire Set
-  Bracing Wire Set

1 Mark and drill suspension points in the soffit.

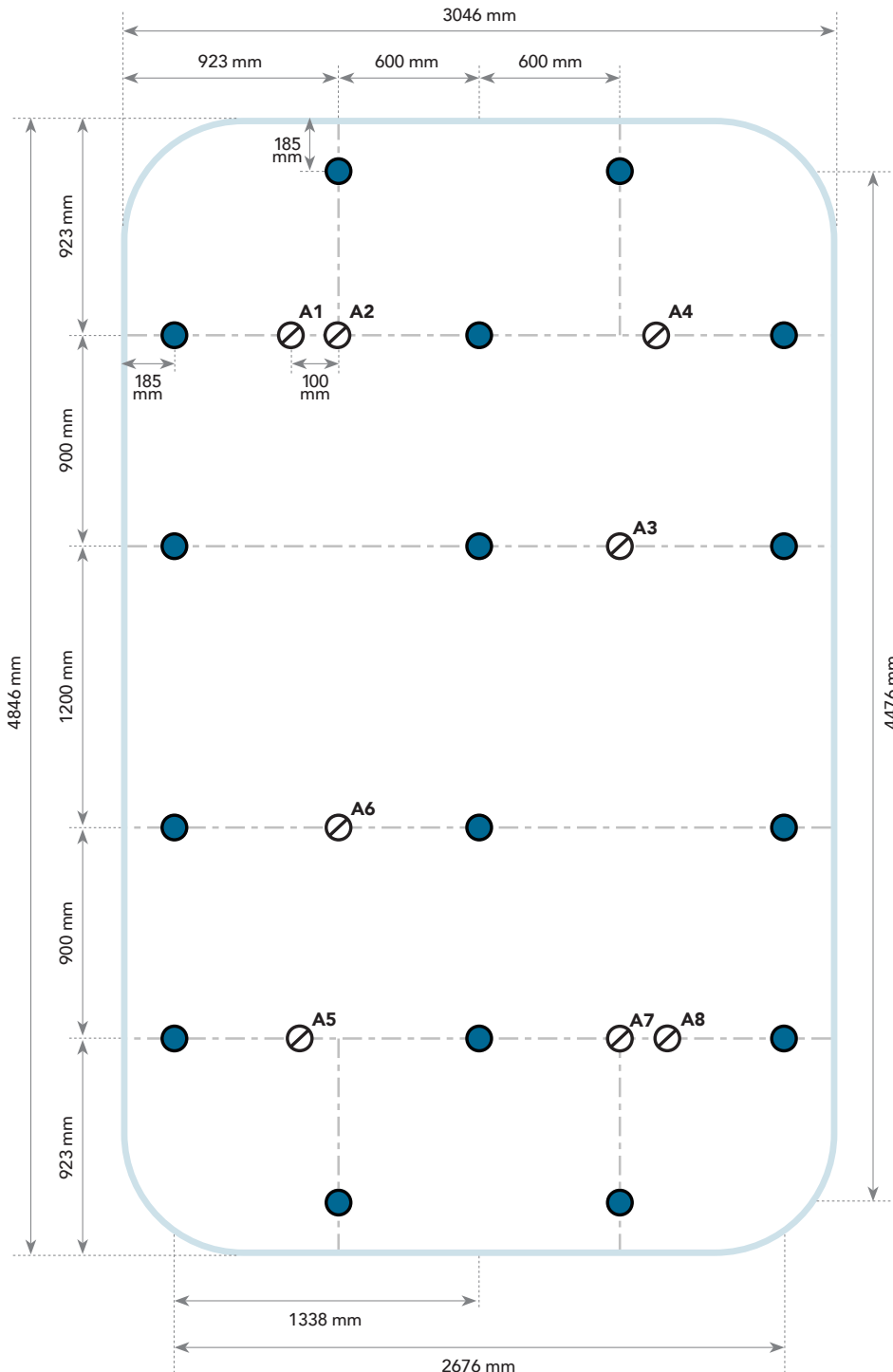

Ceiling drilling plan.





When attaching the suspension sets, ensure to distinguish between vertical and bracing wire sets.

ATTENTION



To attach the suspension, the end of the ceiling anchors needs to be M8. These anchors are not supplied by Rockfon. The holes in the suspension are Ø8,2 mm.

2. 3600 x 4200

-  Frame Profile
-  Carrier Profile
-  Vertical Wire Set
-  Bracing Wire Set

1 Mark and drill suspension points in the soffit.

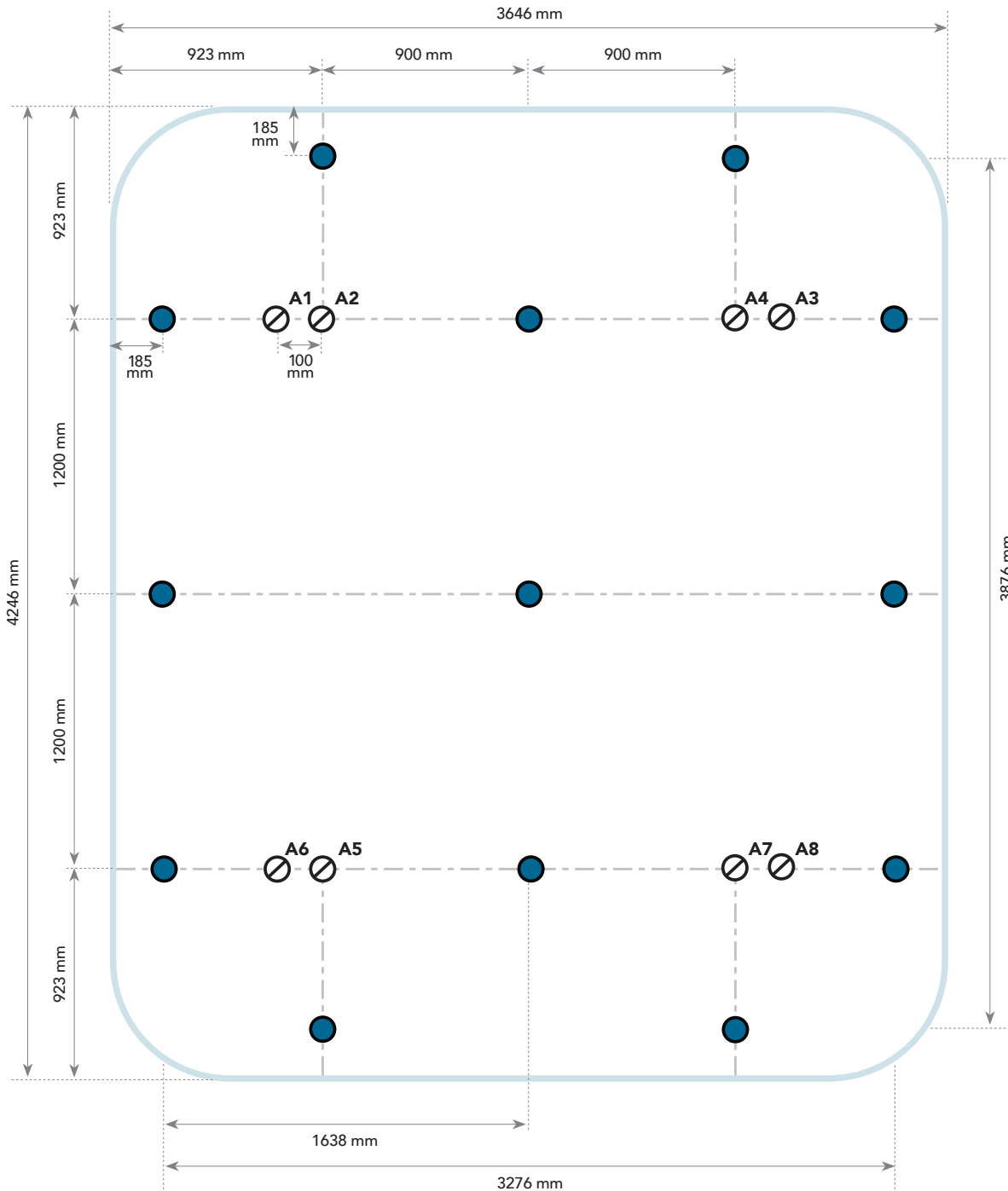

Ceiling drilling plan.





When attaching the suspension sets, ensure to distinguish between vertical and bracing wire sets.

ATTENTION



To attach the suspension, the end of the ceiling anchors needs to be M8. These anchors are not supplied by Rockfon. The holes in the suspension are Ø8,2 mm.

3. 4800 x 4800

-  Frame Profile
-  Carrier Profile
-  Vertical Wire Set
-  Bracing Wire Set

1 Mark and drill suspension points in the soffit.

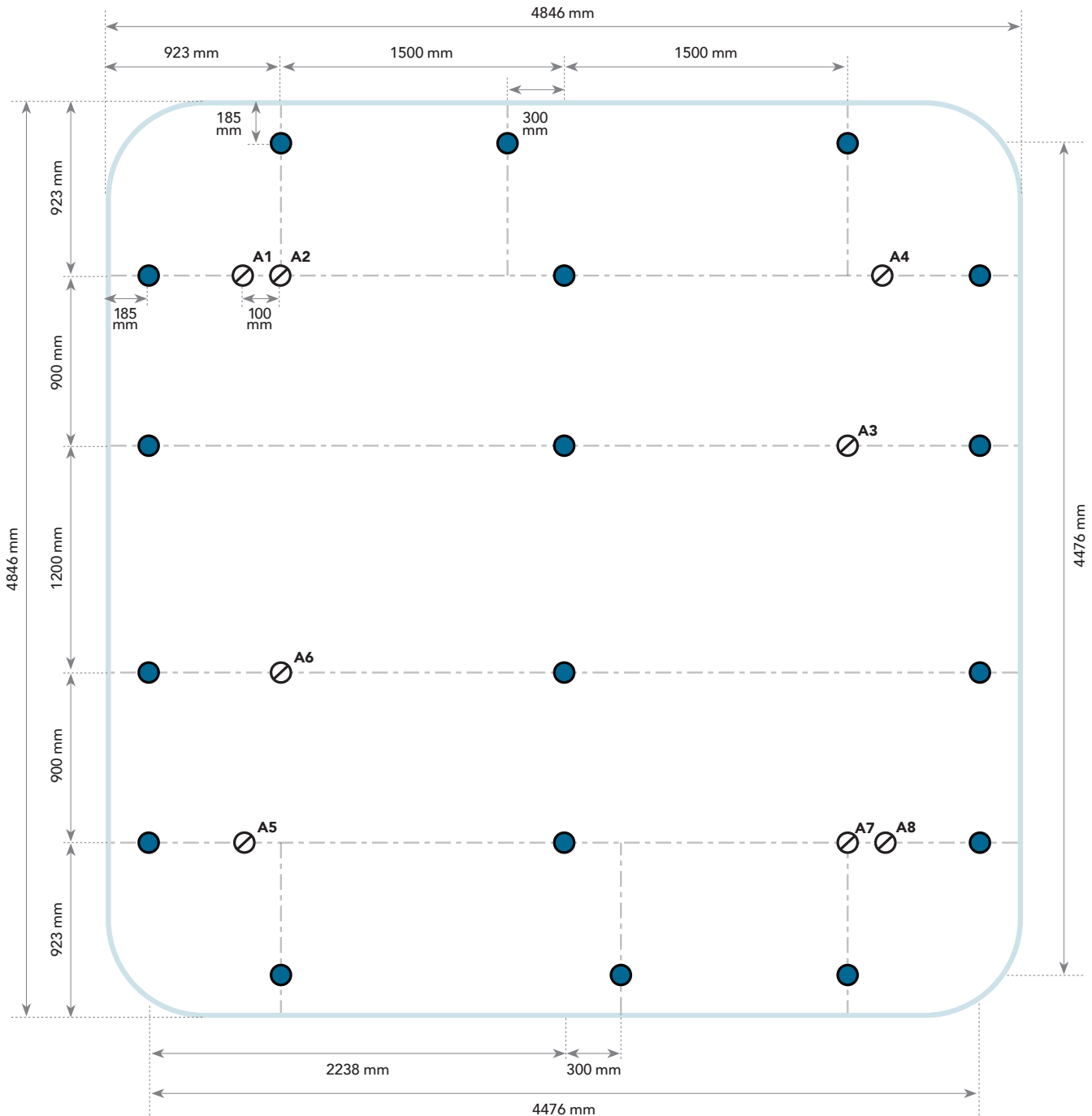





Ceiling drilling plan.

When attaching the suspension sets, ensure to distinguish between vertical and bracing wire sets.

ATTENTION 

To attach the suspension, the end of the ceiling anchors needs to be M8. These anchors are not supplied by Rockfon. The holes in the suspension are Ø8,2 mm.

4. 4800 x 7200

-  Frame Profile
-  Carrier Profile
-  Vertical Wire Set
-  Bracing Wire Set

1 Mark and drill suspension points in the soffit.

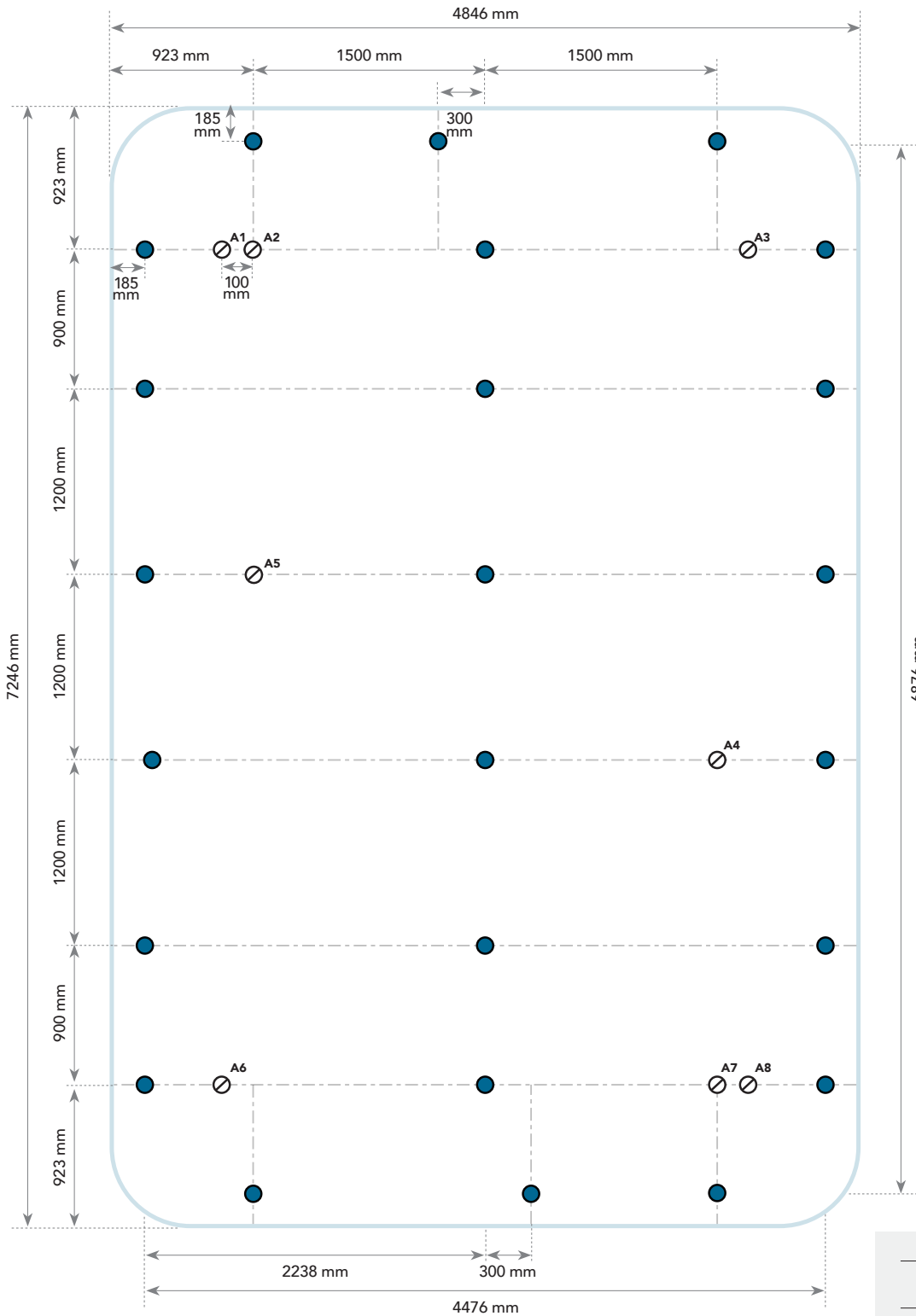

Ceiling drilling plan.

When attaching the suspension sets, ensure to distinguish between vertical and bracing wire sets.

ATTENTION 

To attach the suspension, the end of the ceiling anchors needs to be M8. These anchors are not supplied by Rockfon. The holes in the suspension are Ø8,2 mm.

APPLICABLE FOR ALL DIMENSIONS

2 Suspend Carrier Profiles with Vertical Wire Set.

ATTENTION



Note that this picture only shows Rockfon Hub dimension 3600 x 4200 mm.

All dimensions:

- 3000 x 4800: 4 main carriers
- 3600 x 4200: 3 main carriers
- 4800 x 4800: 4x2 main carriers (see detail x)
- 4800 x 7200: 6x2 main carriers (see detail x)

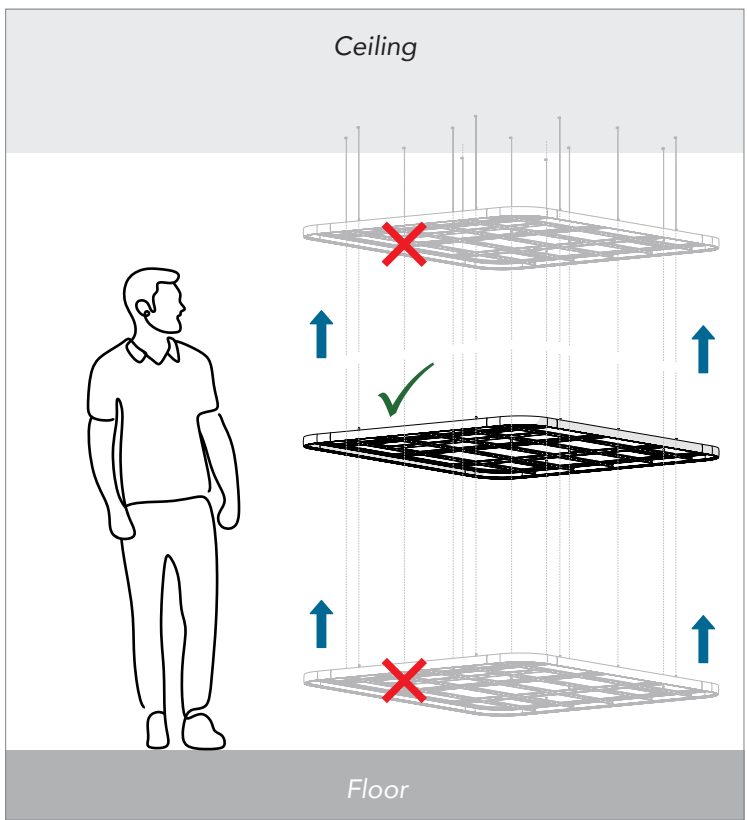
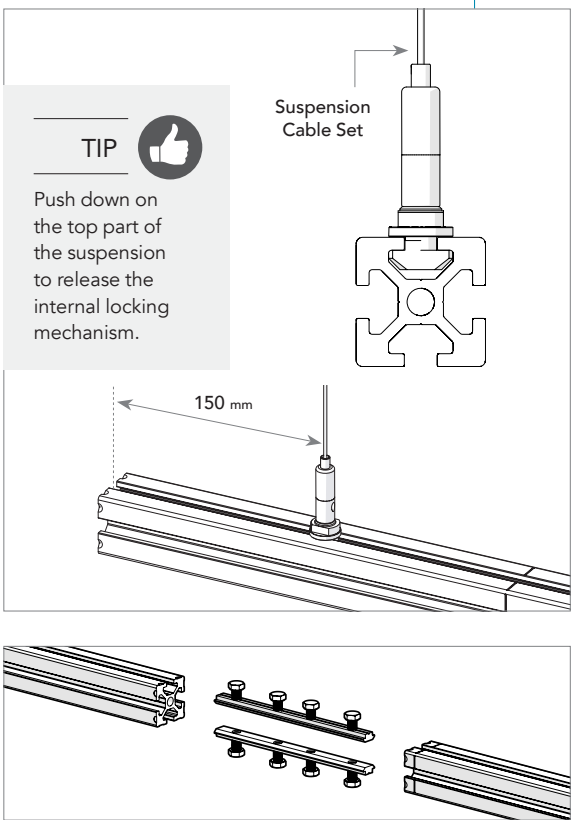
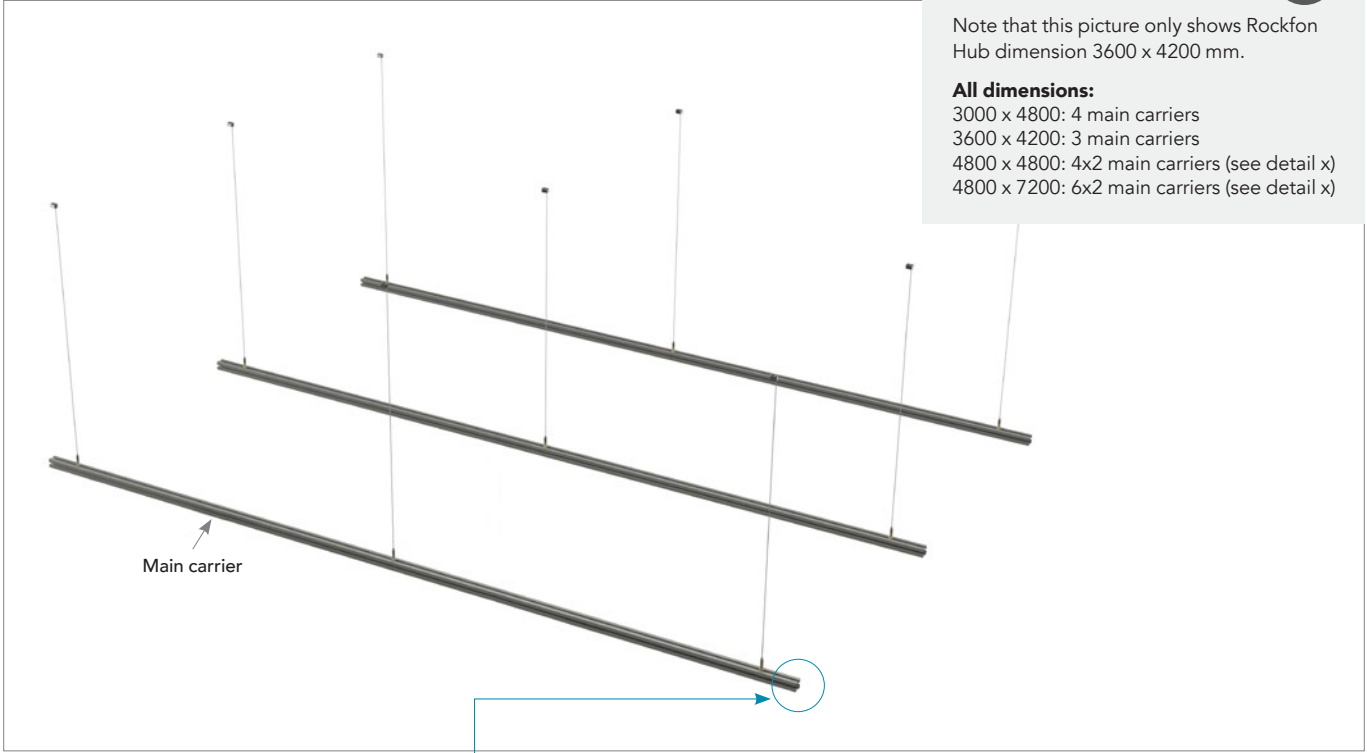

Detail x.
Use two Profile Connectors to connect two Carrier Profiles. Make sure to alternate connecting joints of the Carrier Profiles (see page 18 & 19).

Note that the installation of Rockfon Hub can be done at waist level. When finalized, the Hub is lifted into final position and the tiles are installed (see step 9).

APPLICABLE FOR ALL DIMENSIONS

3 Attach short carriers to main carriers and suspend with vertical wire set.

ATTENTION



Note that this picture only shows Rockfon Hub dimension 3600 x 4200 mm.

All dimensions:

- 3000 x 4800: 4 short carriers
- 3600 x 4200: 4 short carriers
- 4800 x 4800: 6 short carriers
- 4800 x 7200: 6 short carriers

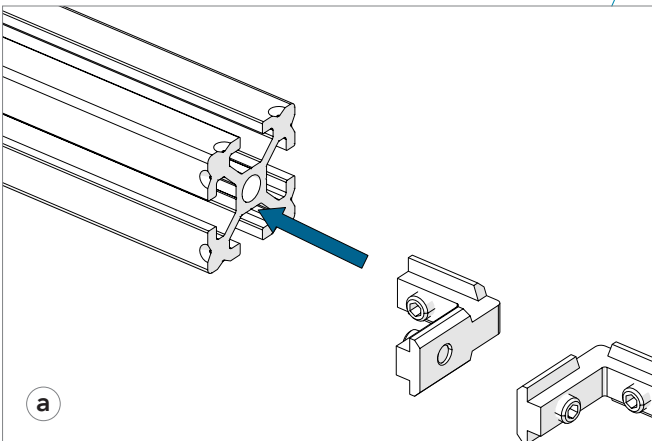
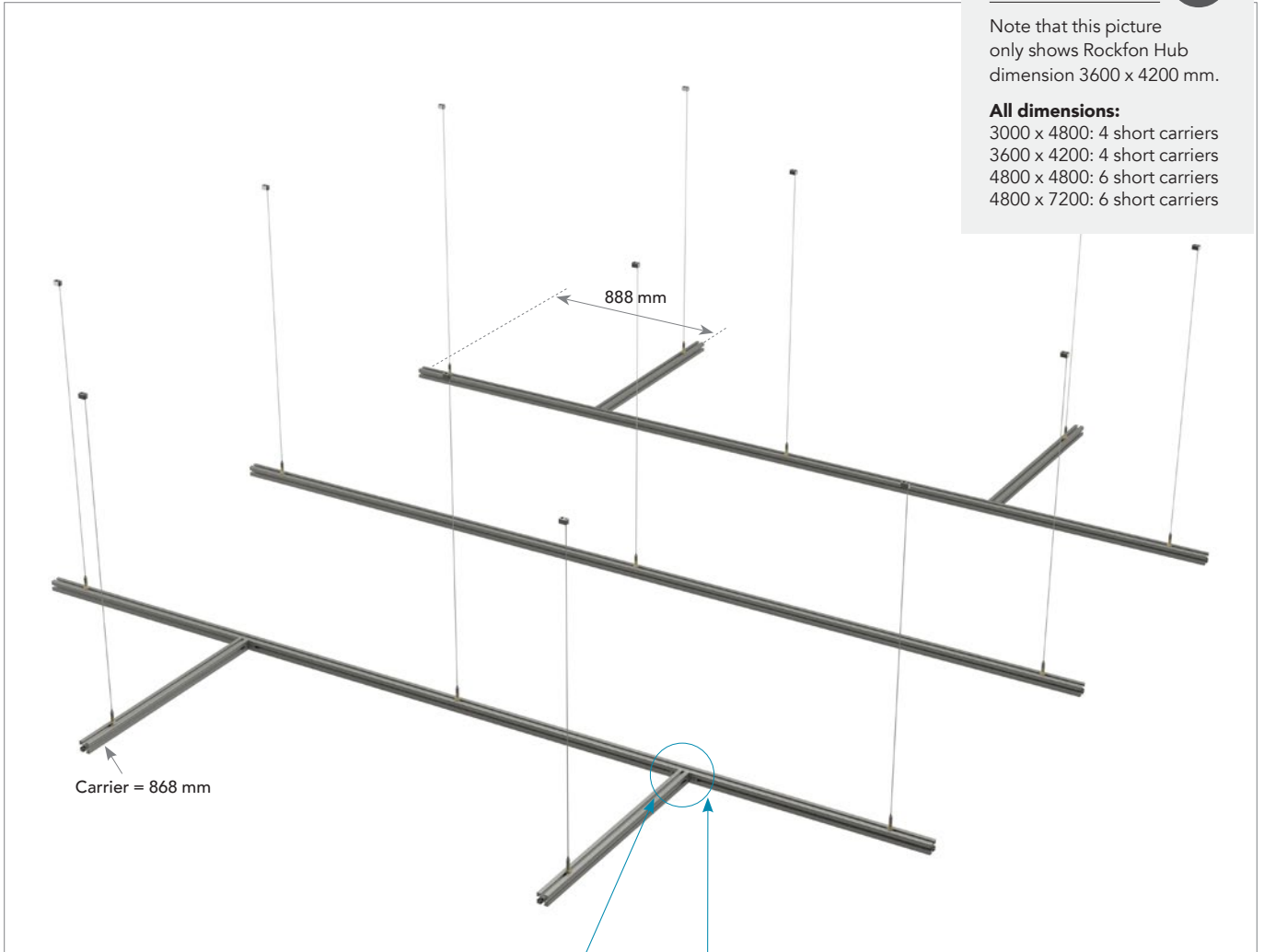

Use the Inter Connector R to connect the short Carrier Profiles to the main Carrier Profiles. Raising and lowering the suspension to roughly the same height can help make step 4 easier.

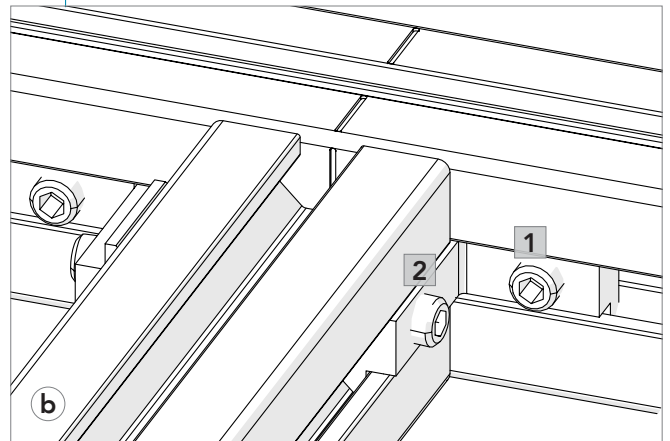

Make sure to use the mark on the carriers for proper alignment. First fasten 1, then 2.

APPLICABLE FOR ALL DIMENSIONS

4a Connect the Frame Profiles and attach them to the Carrier Profiles.

ATTENTION



Note that this picture only shows Rockfon Hub dimension 3600 x 4200 mm.

Detail a / b:

- 3000 x 4800: 12x / 8x
- 3600 x 4200: 10x / 8x
- 4800 x 4800: 14x / 8x
- 4800 x 7200: 18x / 10x

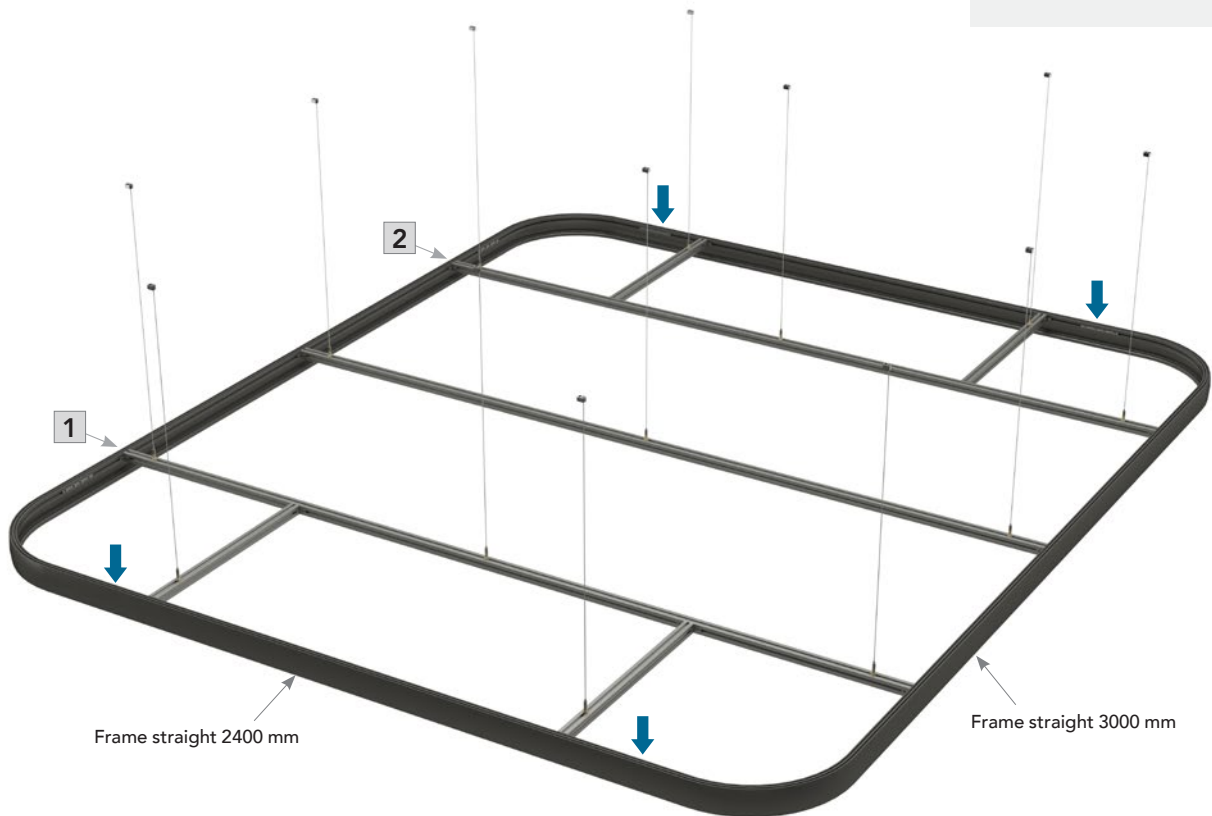

Note: The profile connector's location at these floating ends should be adjusted to shift the fixing screw hole and align it with the profile joints. Please refer to Page 22, detail (2) for more information.

ATTENTION



Curtain rollers to be inserted before closing the frame, if applicable.

TIP



Markings on the profiles can be used to line up the frame on the carriers.

APPLICABLE FOR ALL DIMENSIONS

4b Connect the Frame Profiles and attach them to the Carrier Profiles.

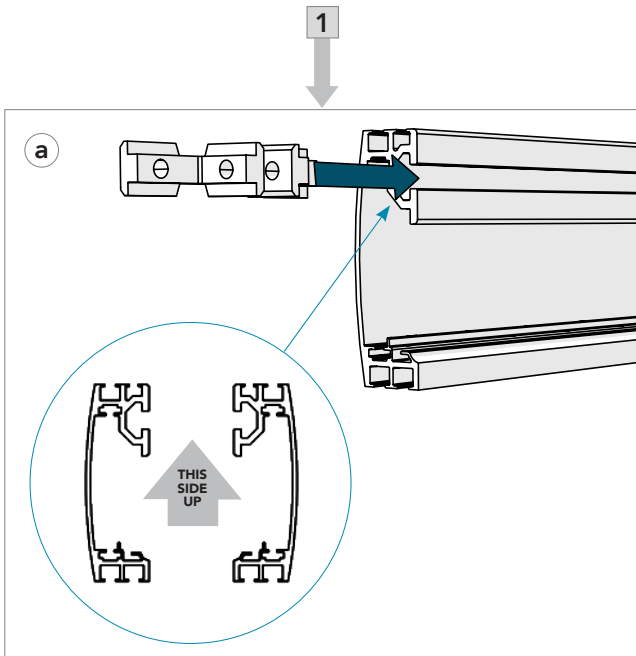

Add the correct amount of Inter Connectors R to the Frame Profiles.

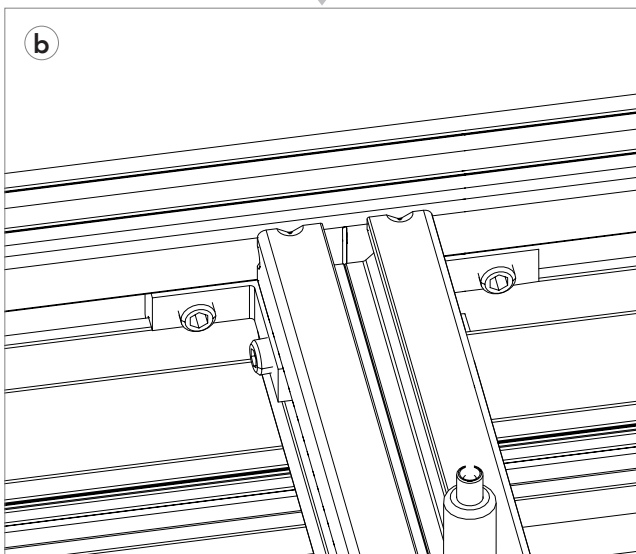

Connect the Frame Profiles to the Carrier Profiles using the Inter Connectors R.
Note: the marking on the frame profile.

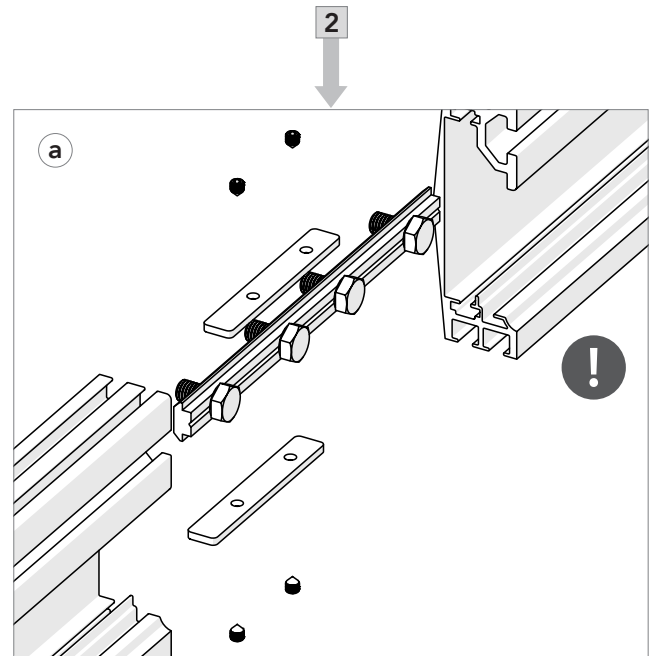

Use the Frame Profile with the Coupling Screws to tighten the seam between the frame profiles. See step 6 on page 16 for the correct order of closing the frame.

- 1: Inserting frame profile couplings top & bottom with profile connector all together.
- 2: Tighten up the bottom frame profile coupling with coupling screws.
- 3: Tighten up the top frame profile coupling with coupling screws.
- 4: Align & tighten up profile connectors.

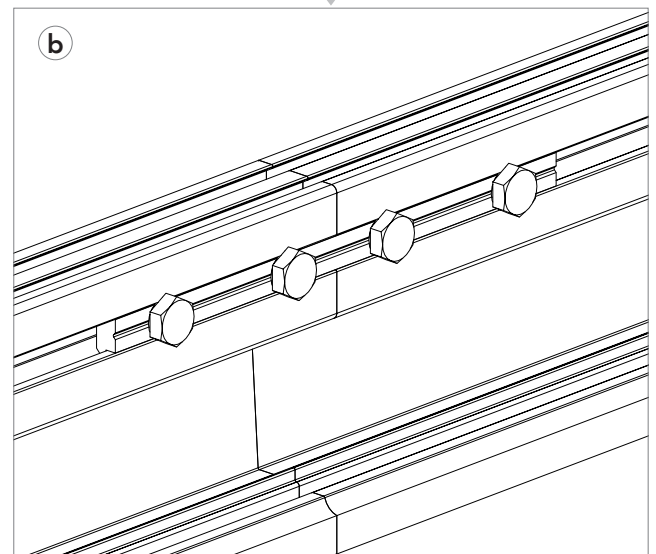

Tighten the Profile Connector to strengthen the coupling.
Note: please consider the special recommendation in drawing nr. 2, page 21.

APPLICABLE FOR ALL DIMENSIONS

5 If applicable, insert curtain rollers before closing the frame.

ATTENTION



If felt is desired for the project go to page 30 for instructions.

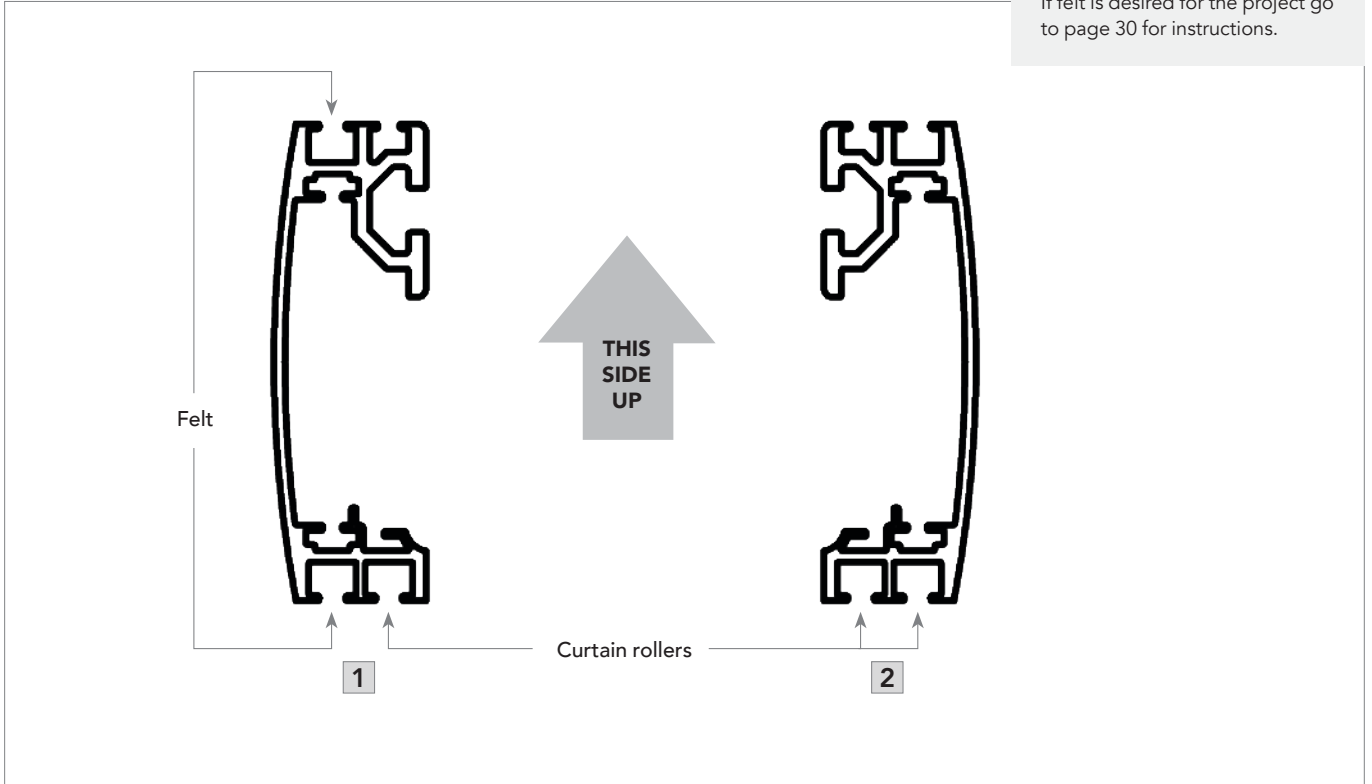

The curtain rollers should be inserted as shown above.
Option 1 = felt + curtains.
Option 2 = curtains only (single or double).

APPLICABLE FOR ALL DIMENSIONS

6 Closing the frame.

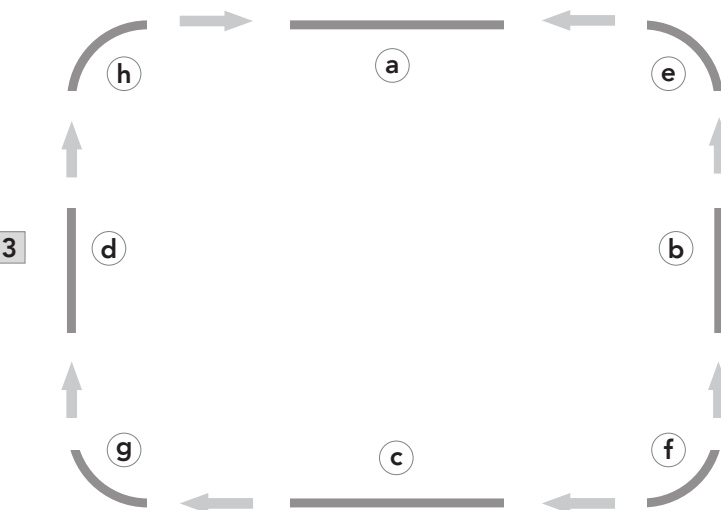
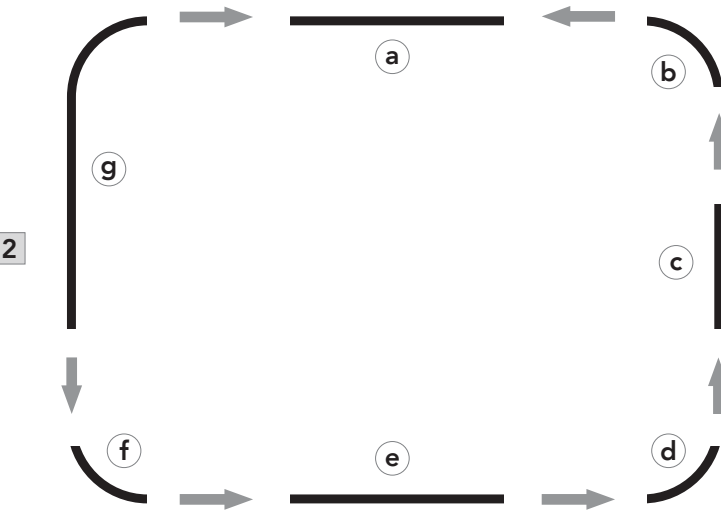
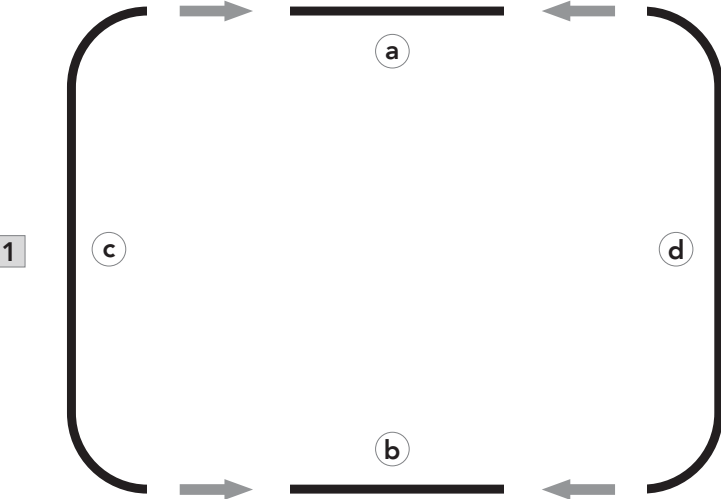

ATTENTION







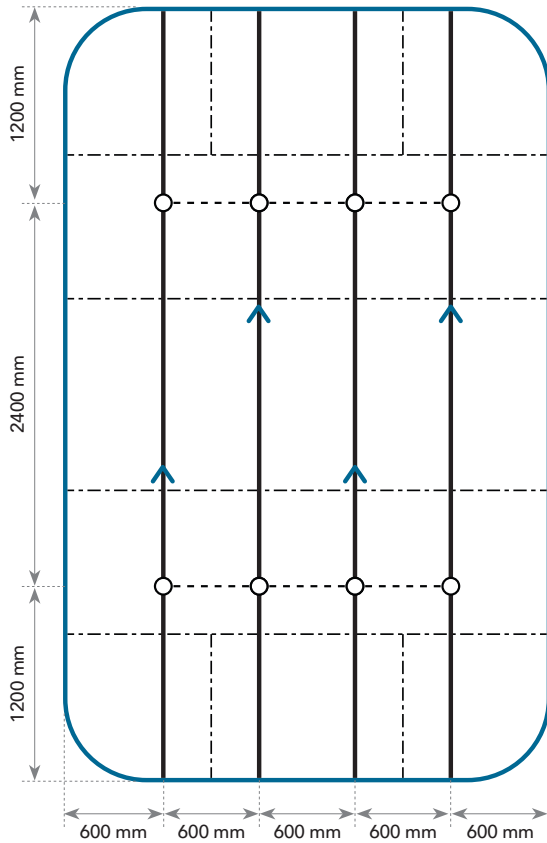

The order in which the frame is closed is important, otherwise the frame corners will not fit.

For closing the frame, use method 1 or method 2. Method 3 is incorrect.

1. 3000 x 4800

7 Cut the Main runner T24 Click/Hook 3600 according to the drawing below.



-  Frame Profile
-  Carrier Profile
-  Main runner T24 Click/Hook 3600
-  Cross tee T24 Click 600 mm
-  Main runner connection joint

ATTENTION 

Make sure to alternate the connection joints of the Main runners.

Cutting of Main runner

Note that the firebreaks are cut off.

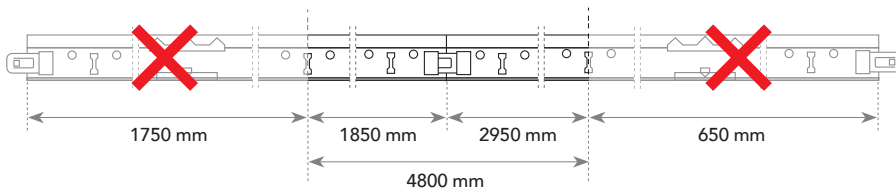

ATTENTION 



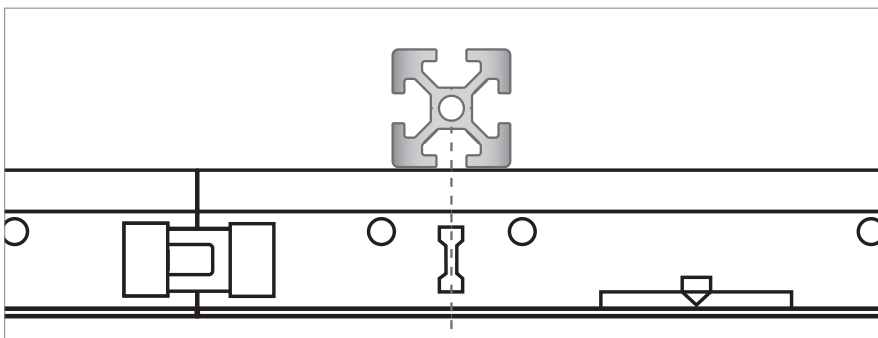

Line up the slots of the Main runner T24 Click/Hook 3600 with the center of the Carrier Profiles.

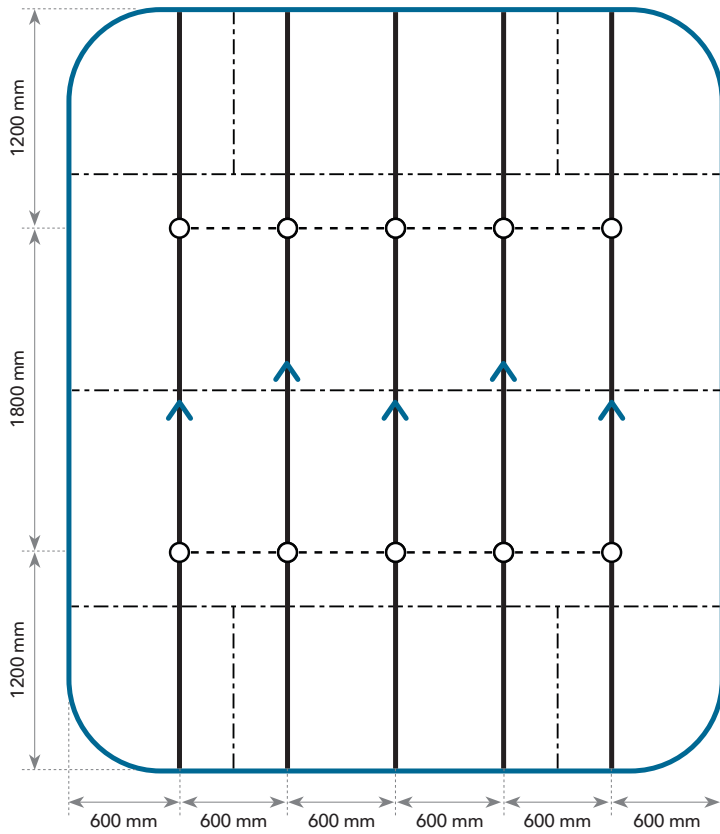

2. 3600 x 4200

7 Cut the Main runner T24 Click/Hook 3600 according to the drawing below.



-  Frame Profile
-  Carrier Profile
-  Main runner T24 Click/Hook 3600
-  Cross tee T24 Click 600 mm
-  Main runner connection joint

ATTENTION 

Make sure to alternate the connection joints of the Main runners.

Cutting of Main runner

Note that the firebreaks are cut off.

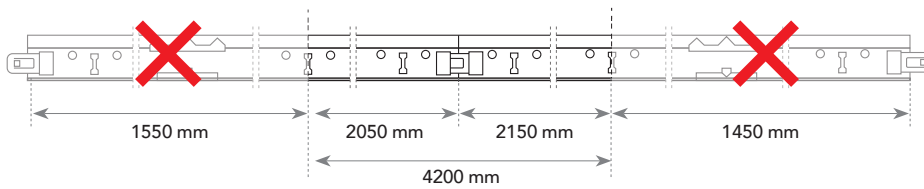

ATTENTION 

Line up the slots of the Main runner T24 Click/Hook 3600 with the center of the Carrier Profiles.

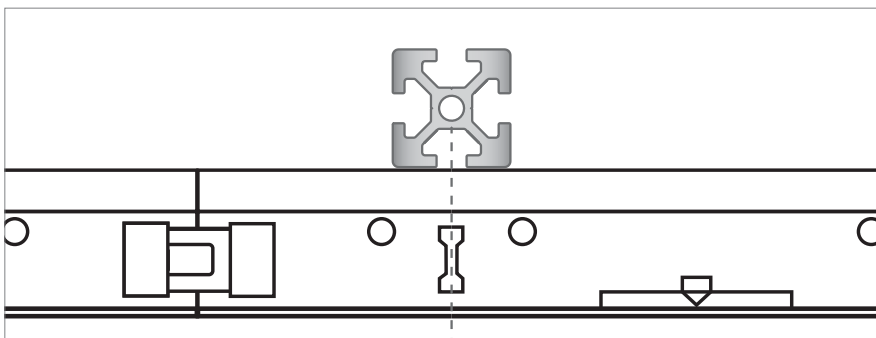

3. 4800 x 4800

7 Cut the Main runner T24 Click/Hook 3600 according to the drawing below.

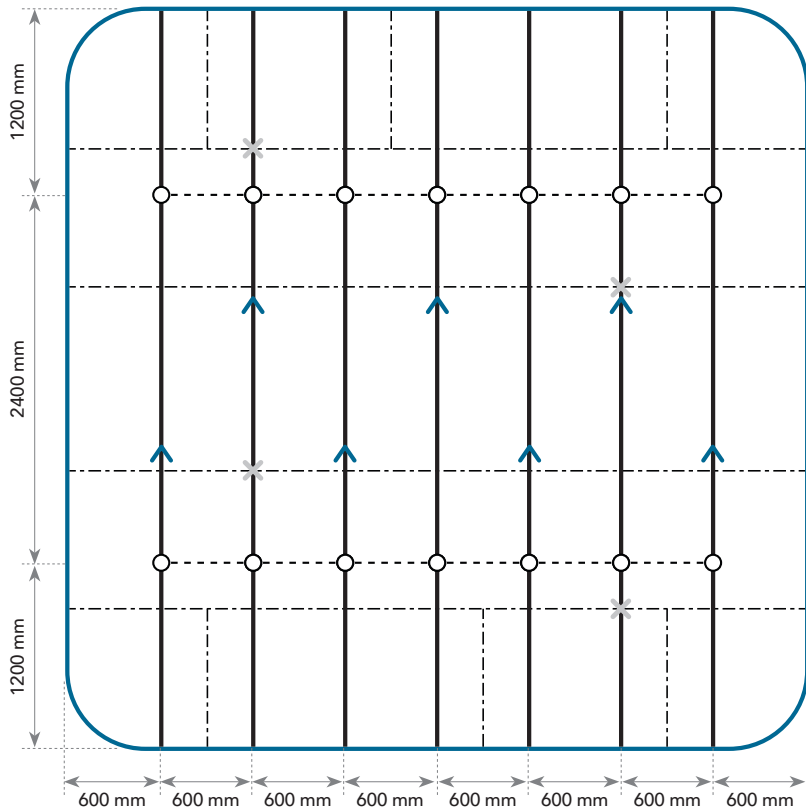

- Frame Profile
- Carrier Profile
- Main runner T24 Click/Hook 3600
- Cross tee T24 Click 600 mm
- Main runner connection joint
- Carrier profile connection joint

ATTENTION

Make sure to alternate the connection joints of the Main runners and Carrier Profiles.

Cutting of Main runner

Note that the firebreaks are cut off.

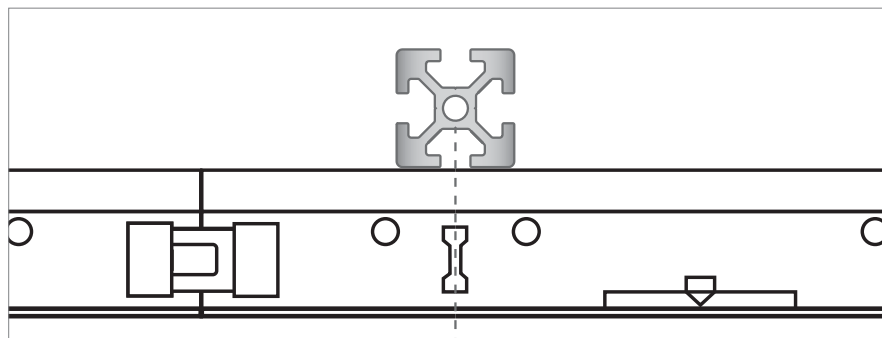
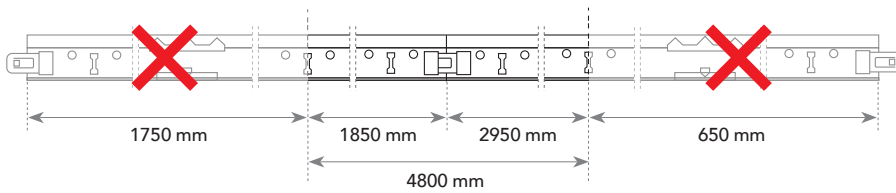





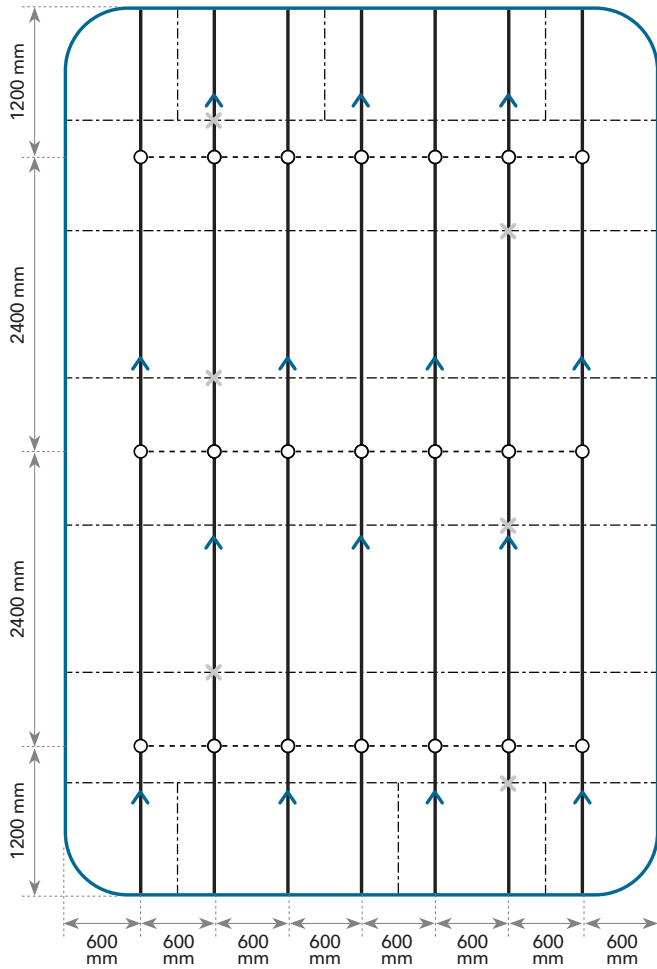

ATTENTION

Line up the slots of the Main runner T24 Click/Hook 3600 with the center of the Carrier Profiles.

4. 4800 x 7200

7 Cut the Main runner T24 Click/Hook 3600 according to the drawing below.



-  Frame Profile
-  Carrier Profile
-  Main runner T24 Click/Hook 3600
-  Cross tee T24 Click 600 mm
-  Main runner connection joint
-  Carrier profile connection joint

ATTENTION 

Make sure to alternate the connection joints of the Main runners and Carrier Profiles.

Cutting of Main runner

Note that the firebreaks are cut off.

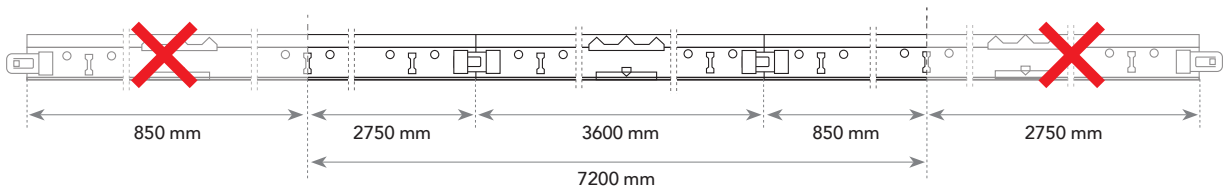

ATTENTION 

Line up the slots of the Main runner T24 Click/Hook 3600 with the center of the Carrier Profiles.

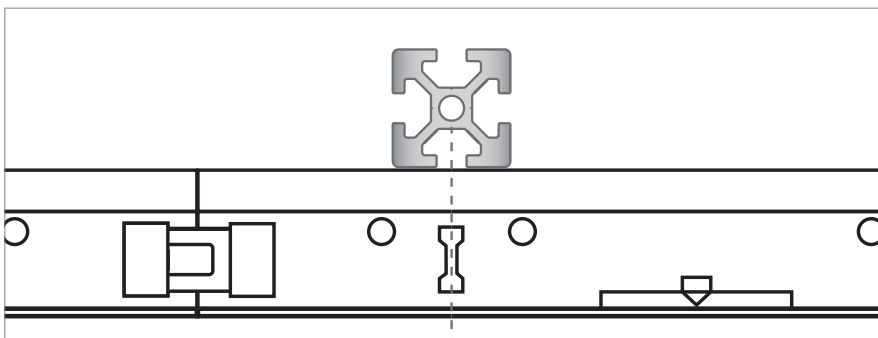

APPLICABLE FOR ALL DIMENSIONS

- 8 Install all Intersection Clips to Carrier Profiles and Frame Profiles and slide in Main runners afterwards.
Install Cross tees according to detail on previous pages.

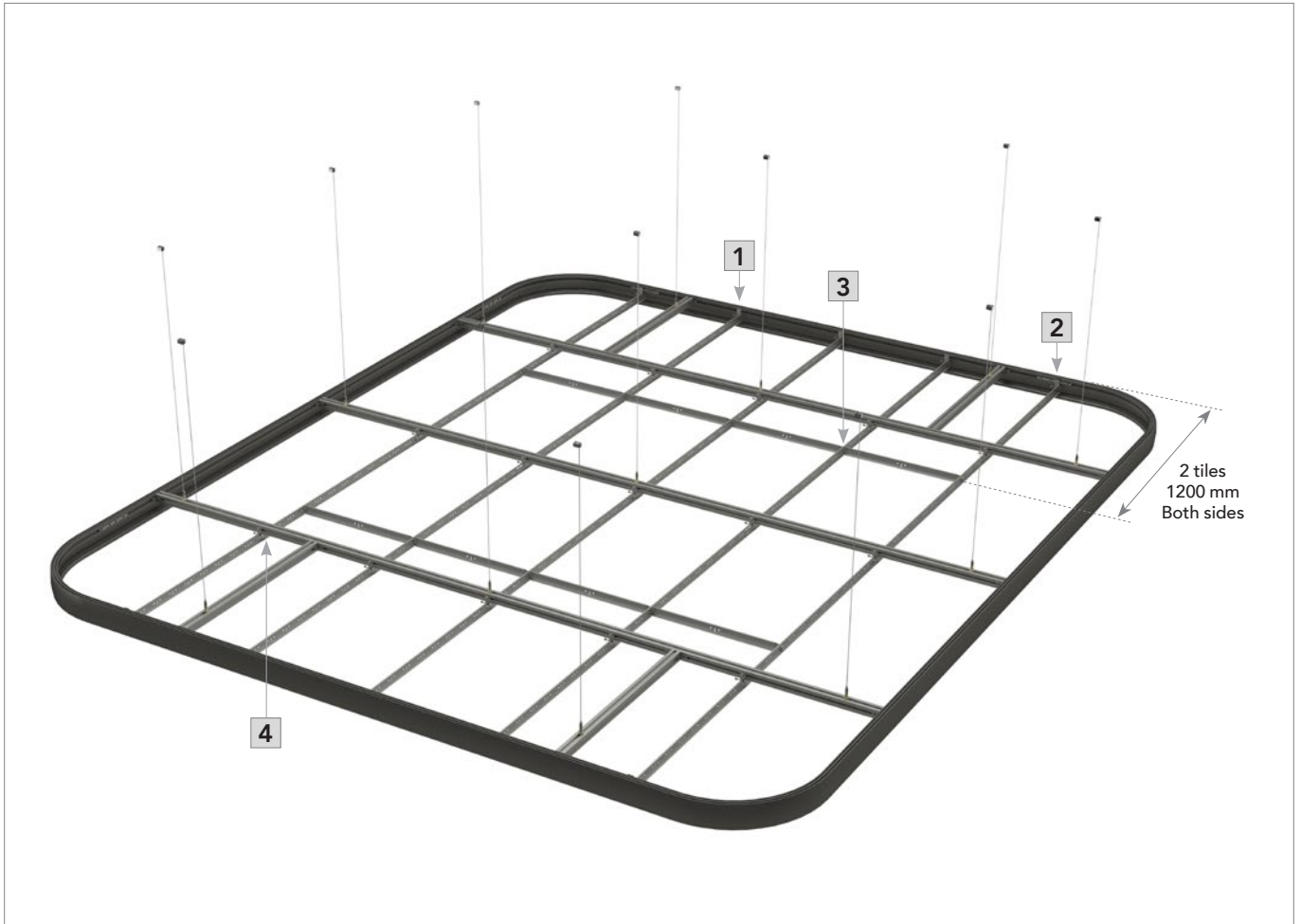

RECOMMENDATION



Tech screw 13 mm recommended.
Not supplied by Rockfon.

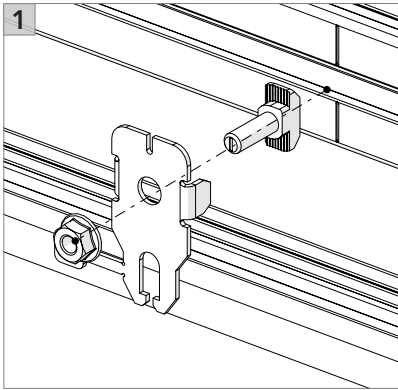

Intersection Clip on Frame Profile.

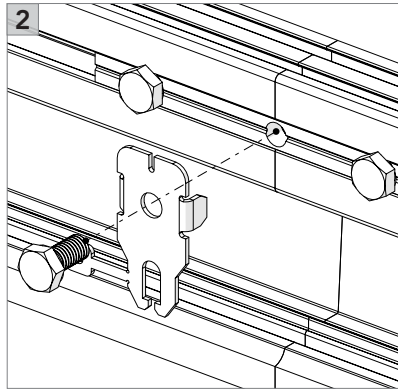

Intersection clip on profile connector.

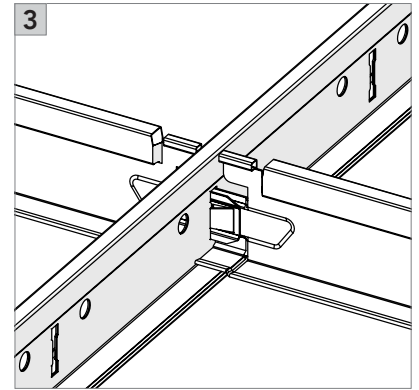

Cross tees clicked in Main runner.

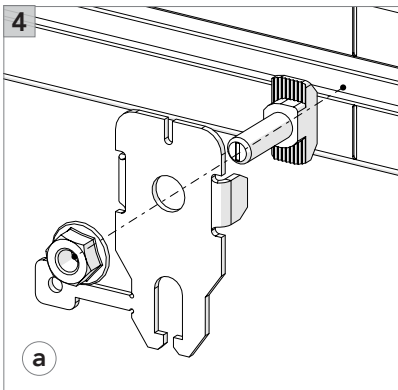

Intersection Clip on Carrier Profile.

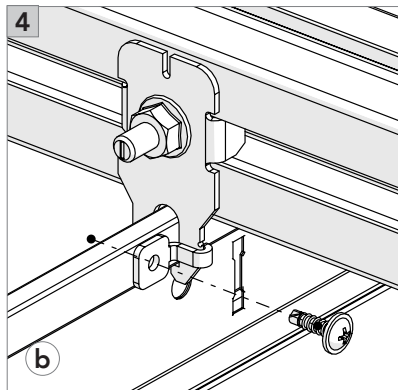

Use the thumbtab on the Intersection Clip clip and fixate the Main runners (2x per merged Main runner - in each end of the original Main runner) using a selfdrilling screw.

ATTENTION



Note that the picture on the previous page only shows Rockfon Hub dimension 3600 x 4200 mm.

Detail 1 / 2 / 3 / 4a / 4b:

3000 x 4800: 4x / 4x / 4x / 16x / 8x
 3600 x 4200: 6x / 4x / 6x / 15x / 10x
 4800 x 4800: 10x / 4x / 10x / 28x / 14x
 4800 x 7200: 10x / 4x / 15x / 42x / 21x

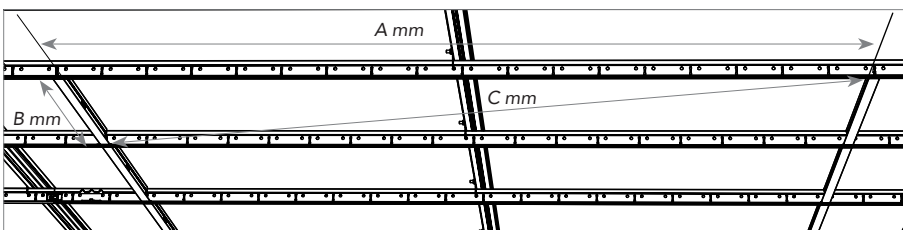

Measure the diagonals to square the grid.

| Dimensions (A x B) | Diagonal (C) | Tolerance |
|--------------------|--------------|-----------|
| mm | | |
| 1200 x 600 | 1341,64 | +/- 1,0 |
| 1800 x 600 | 1897,37 | |
| 2400 x 600 | 2473,86 | |

APPLICABLE FOR ALL DIMENSIONS

9 Lift the Rockfon Hub into position and level it with a laser.

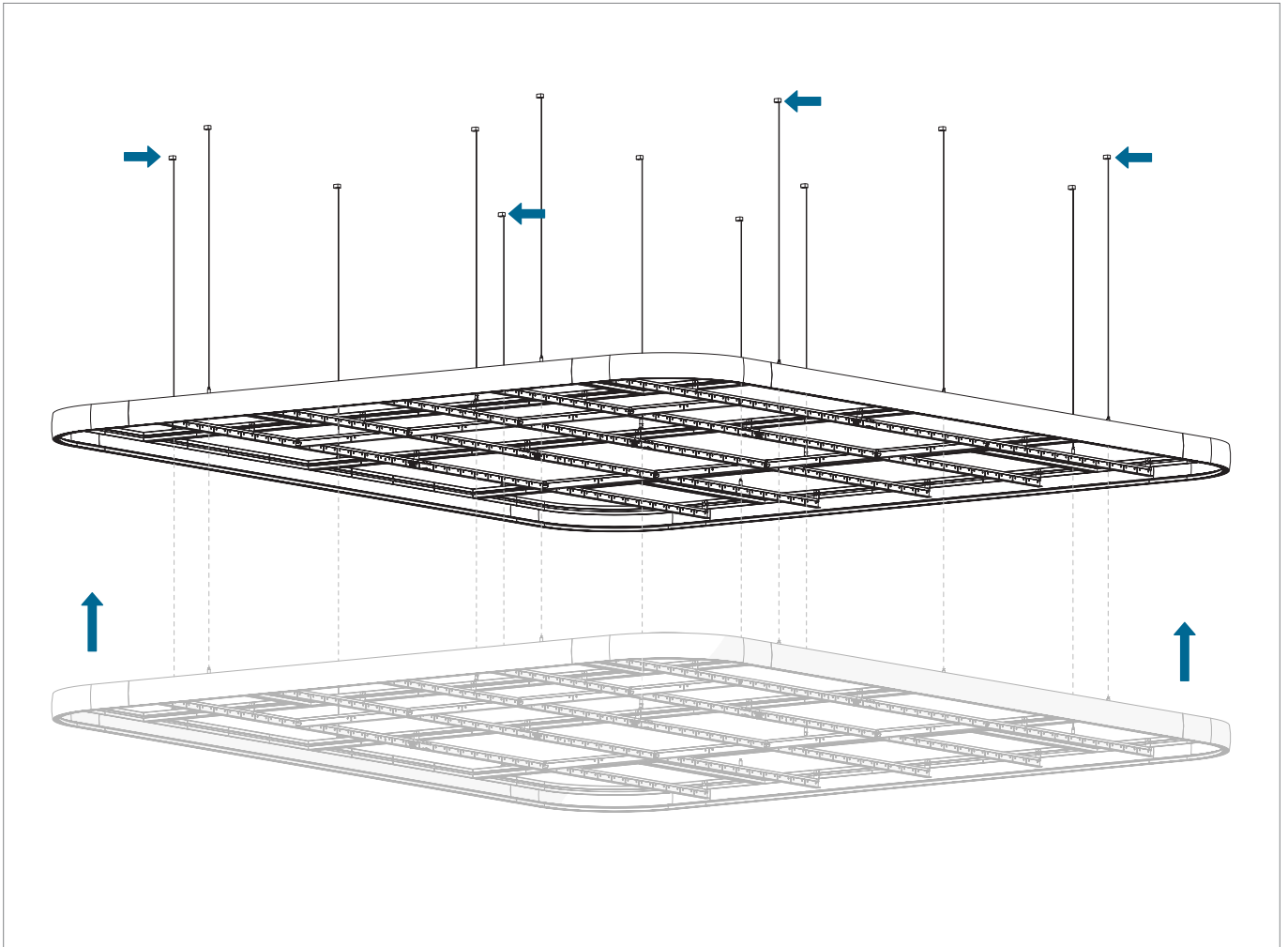

Lift the Rockfon Hub using the 4 straight corner suspension cables (indicated with an arrow) that are connected to the main Carrier Profiles. First lift one side (2 suspension points), then lift the opposite side.

TIP



A gypsum panel hoist can be used to lift the island. Place it in the center of the Frame Profile and push up on one side and tighten outer corner suspensions on that side. Repeat on the opposite side.

APPLICABLE FOR ALL DIMENSIONS

10 Connect & tension Bracing Wire Sets

ATTENTION



Note that this picture only shows Rockfon Hub dimension 3600 x 4200 mm. Number of Bracing Wire Sets needed is similar for all dimensions.

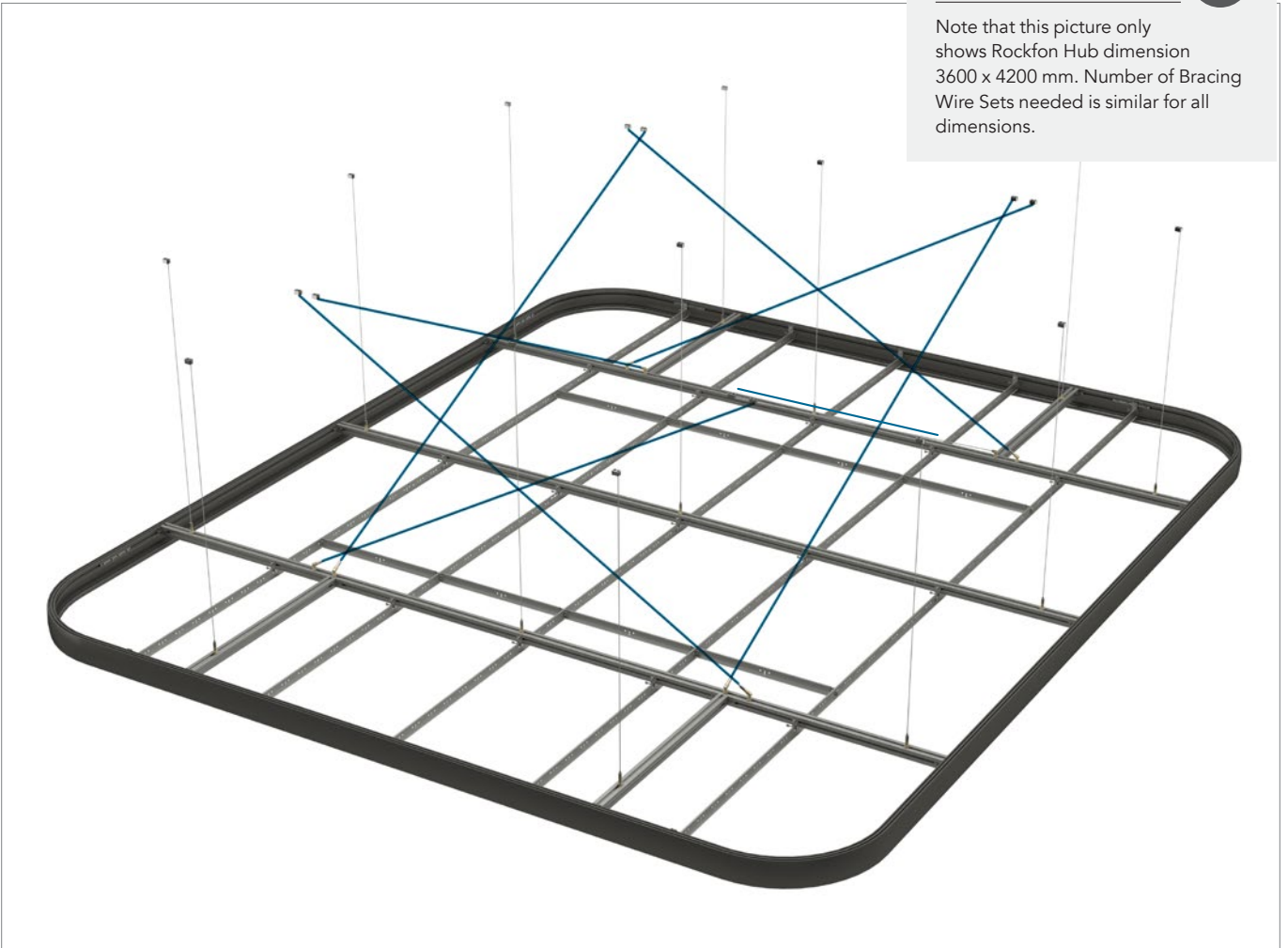

Make sure to tighten opposing Bracing Wire Sets at the same time in order to keep the island from moving.

1. 3000 x 4800

- Frame Profile
- Carrier Profile
- Vertical Wire Set
- Bracing Wire Set

11 Connect & tension Bracing Wire Sets.

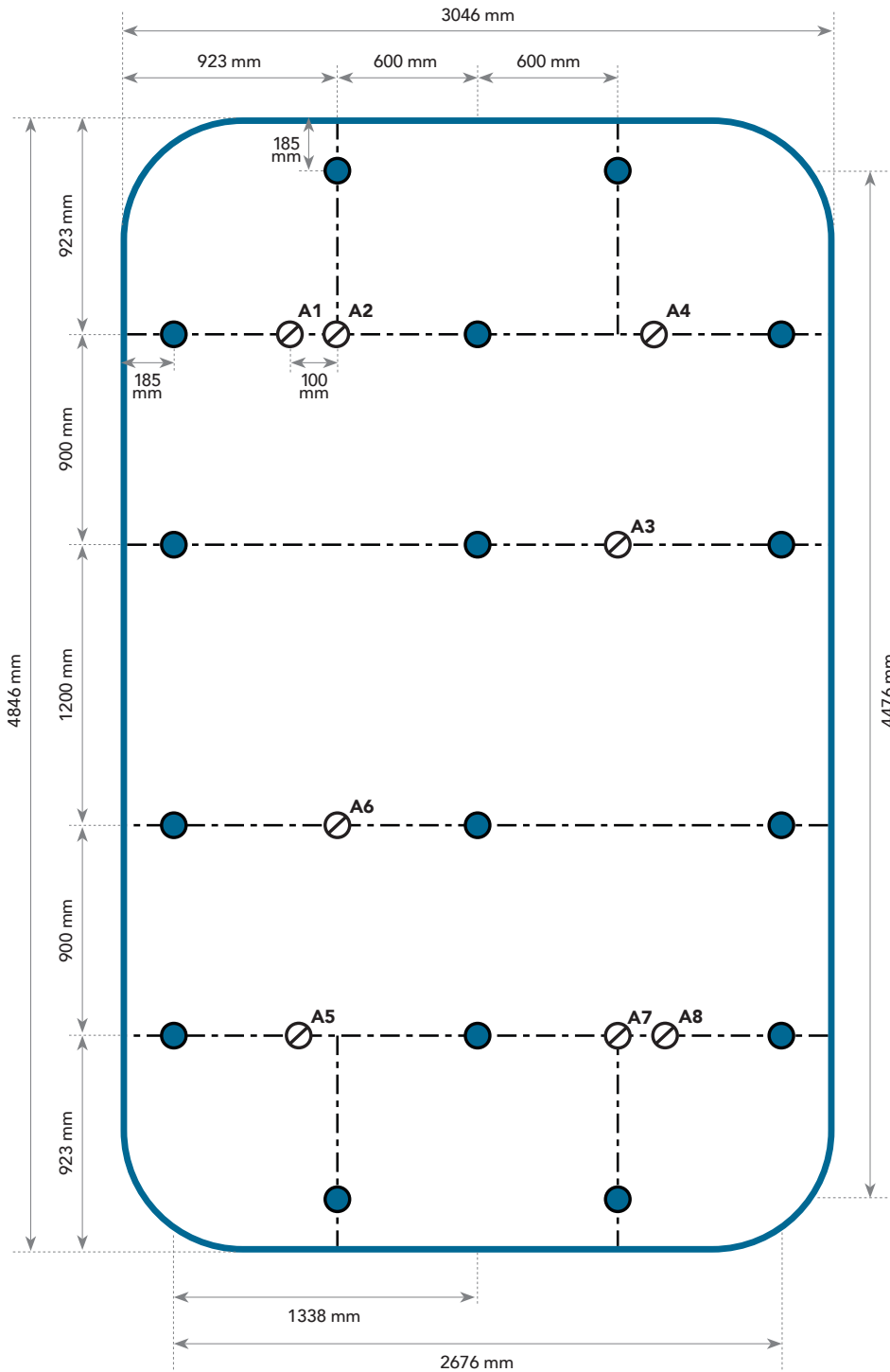

Bracing table

| | | | | | | | | |
|---------|---------|---------|---------|---------|---------|---------|---------|---------|
| Ceiling | A1 | A3 | A2 | A5 | A4 | A7 | A6 | A8 |
| Hub | ↓ A3 | ↓ A1 | ↓ A5 | ↓ A2 | ↓ A7 | ↓ A4 | ↓ A8 | ↓ A6 |

2. 3600 x 4200

- Frame Profile
- Carrier Profile
- Vertical Wire Set
- Bracing Wire Set



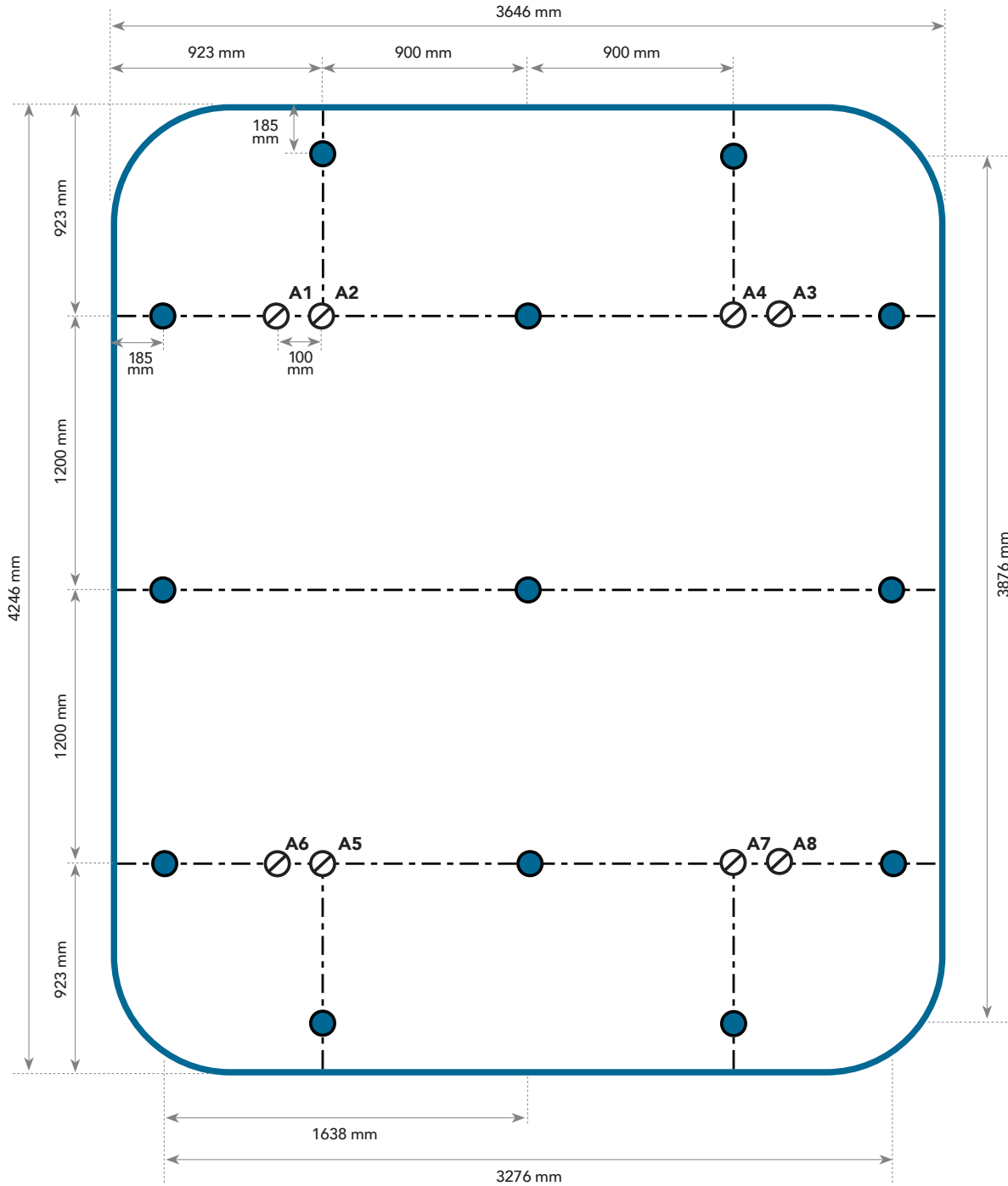

11 Connect & tension Bracing Wire Sets.



Bracing table

| | | | | | | | | |
|---------|------|------|------|------|------|------|------|------|
| Ceiling | A1 | A3 | A2 | A5 | A4 | A7 | A6 | A8 |
| Hub | ↓ A3 | ↓ A1 | ↓ A5 | ↓ A2 | ↓ A7 | ↓ A4 | ↓ A8 | ↓ A6 |

3. 4800 x 4800

-  Frame Profile
-  Carrier Profile
-  Vertical Wire Set
-  Bracing Wire Set

11 Connect & tension Bracing Wire Sets.

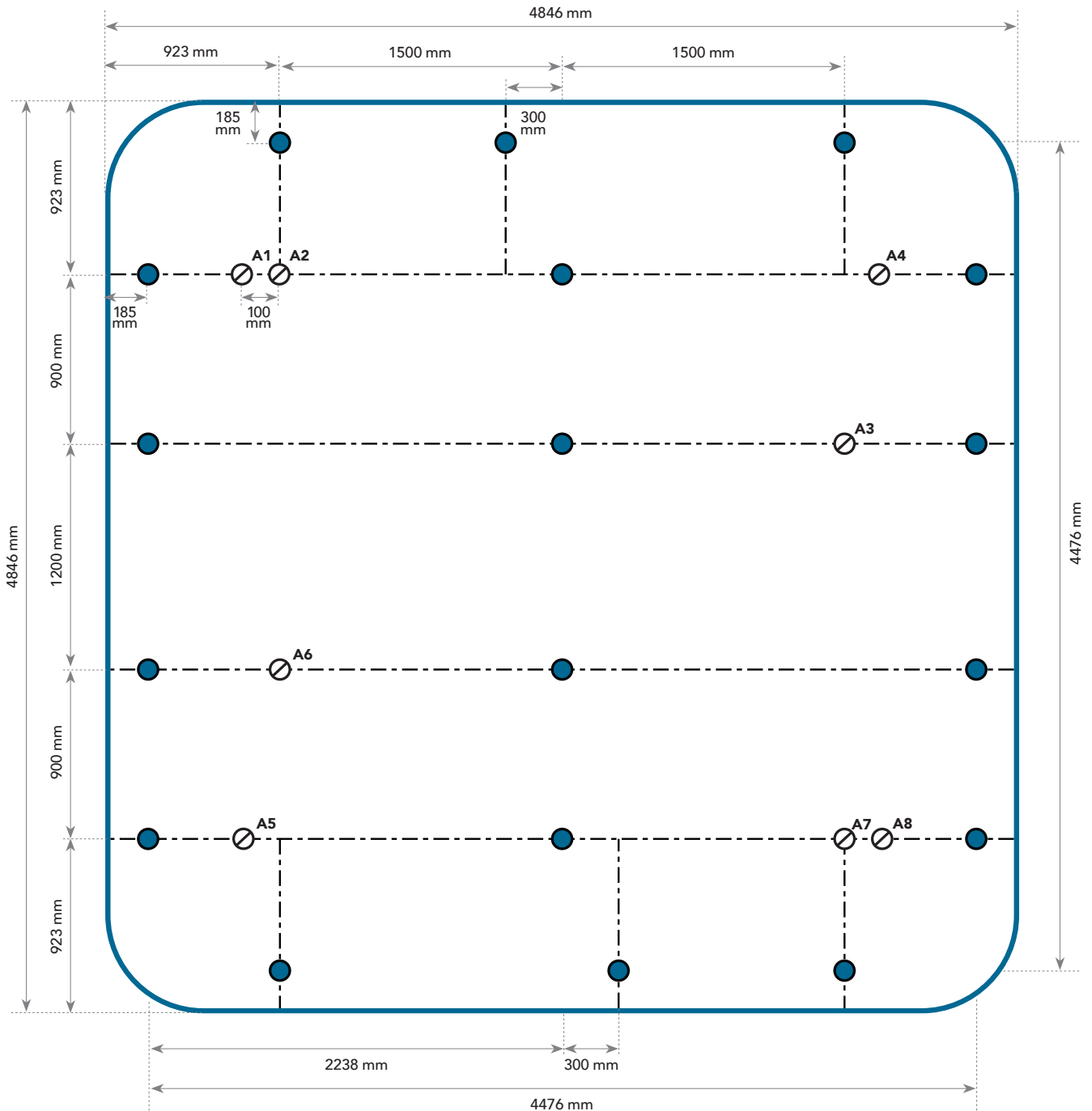

Bracing table

| | | | | | | | | |
|---------|------|------|------|------|------|------|------|------|
| Ceiling | A1 | A3 | A2 | A5 | A4 | A7 | A6 | A8 |
| Hub | ↓ A3 | ↓ A1 | ↓ A5 | ↓ A2 | ↓ A7 | ↓ A4 | ↓ A8 | ↓ A6 |

4. 4800 x 7200

- Frame Profile
- - - Carrier Profile
- Vertical Wire Set
- ⊗ Bracing Wire Set

11 Connect & tension Bracing Wire Sets.

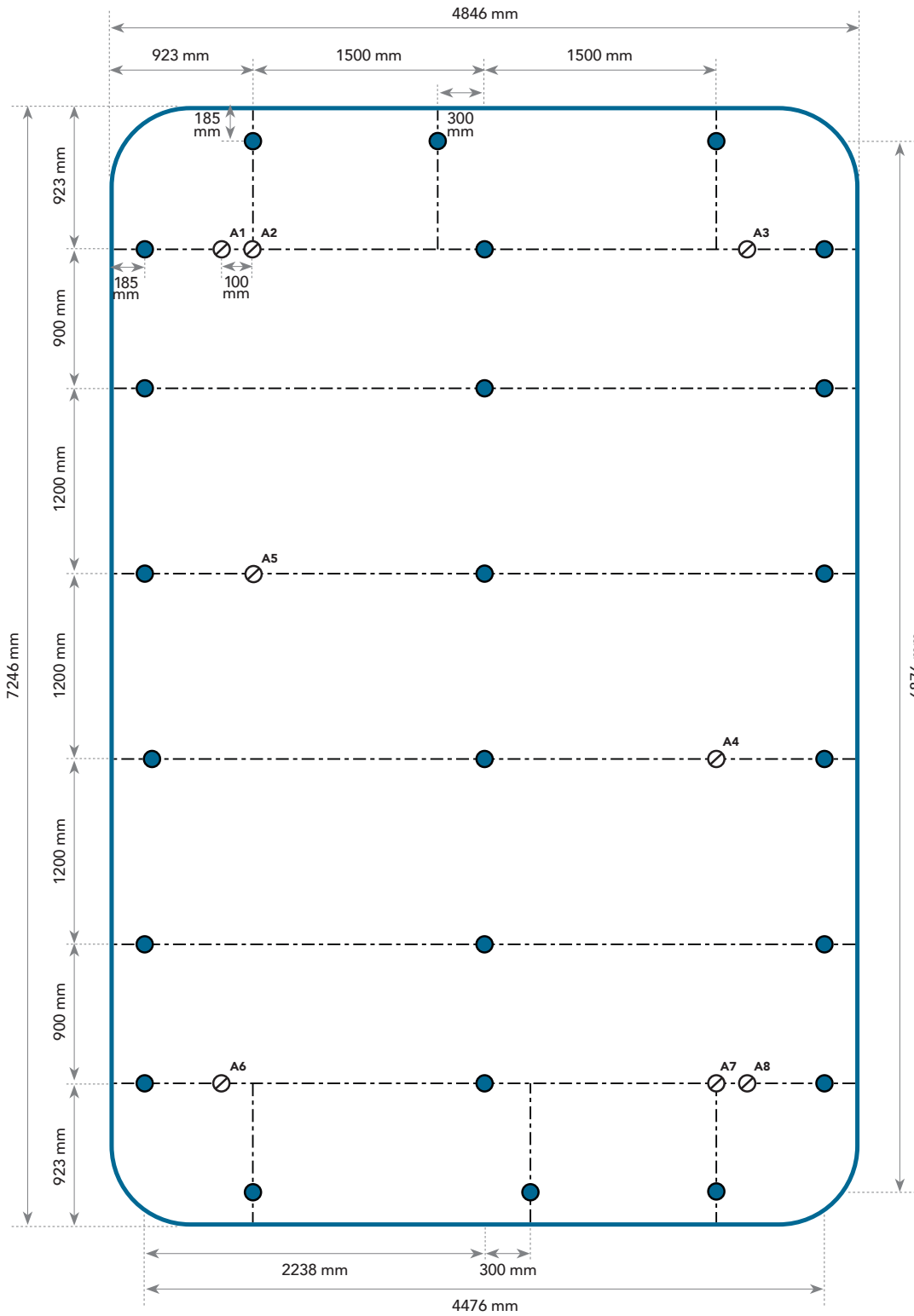

Bracing table

| | | | | | | | | |
|---------|------|------|------|------|------|------|------|------|
| Ceiling | A1 | A3 | A2 | A5 | A4 | A7 | A6 | A8 |
| Hub | ↓ A3 | ↓ A1 | ↓ A5 | ↓ A2 | ↓ A7 | ↓ A4 | ↓ A8 | ↓ A6 |

FINAL INSTALLATION STEPS FOR ALL SIZES

- 1 Cut the tiles using the Cutting Template.

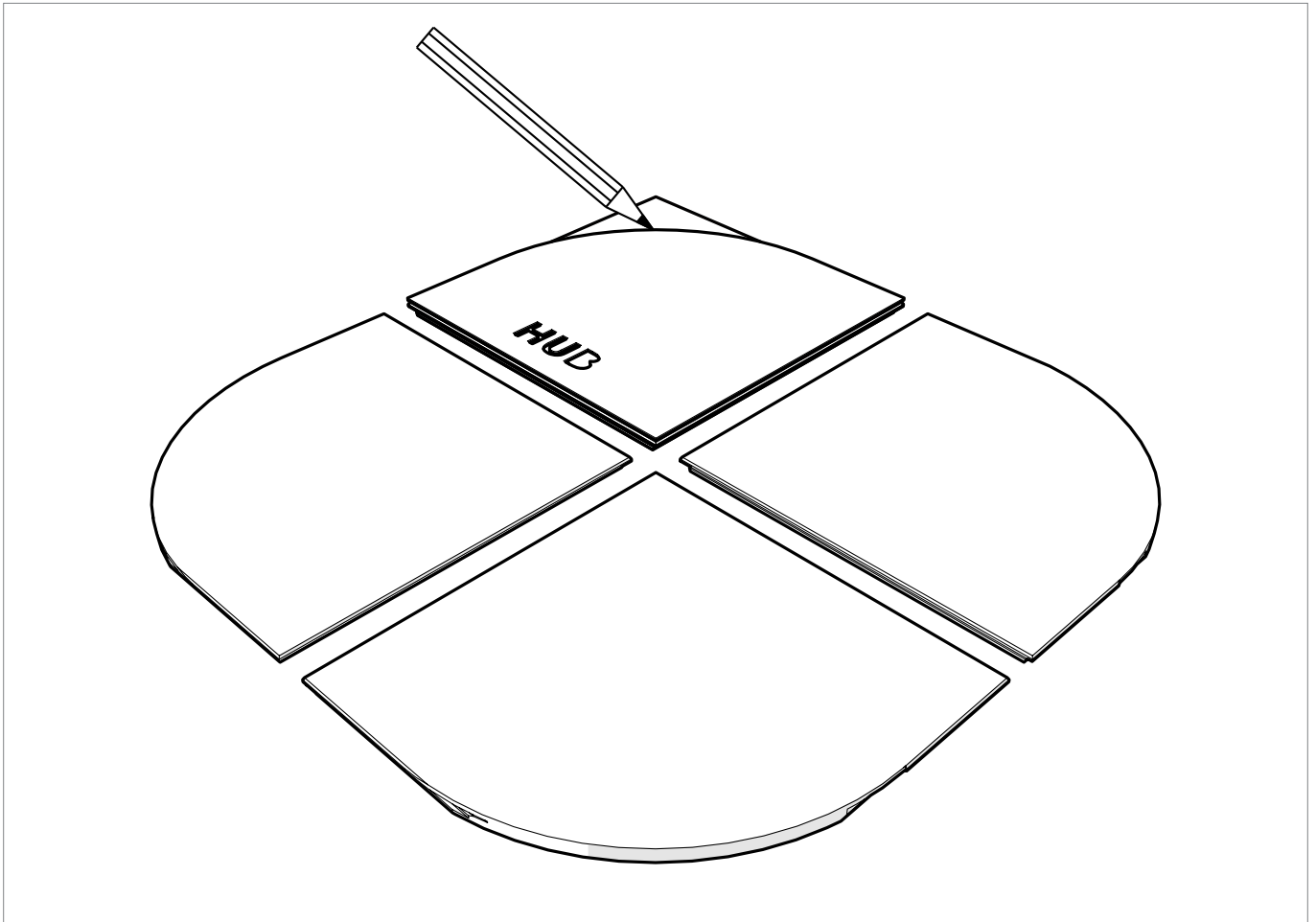

Place four tiles next to each other as shown in the drawing. They should all have the same directionality and have the front side facing up. Then draw all the cutting lines on the tiles. Now all necessary corner tiles are cut.

TIP



Use fresh white gloves to handle the tiles in order to avoid fingermarks.

ATTENTION



When laying out the tiles, make sure they all have the same directionality. The markings on the back should be used as an indication of direction.

ATTENTION



When cutting the tiles separately keep in mind that you have to mirror the direction of the Cutting Template in order to end up with the correct cut.

2 Finish the Rockfon Hub by inserting all the tiles.

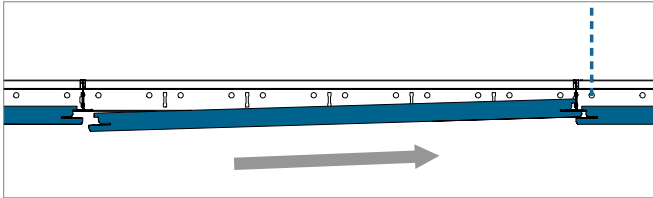

Slide the X edge of the tile into the T profile.

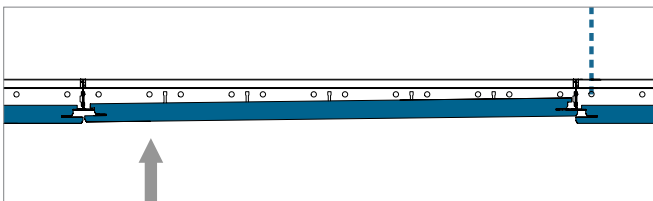

Lift the upper side of the opposite X edge of the tile above the T profile.

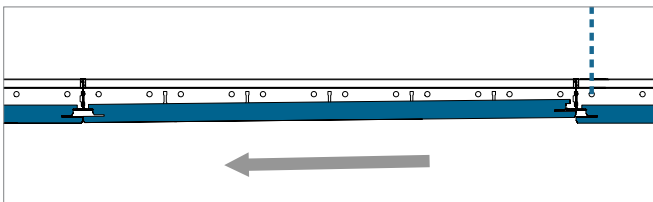

Pull the tile back.

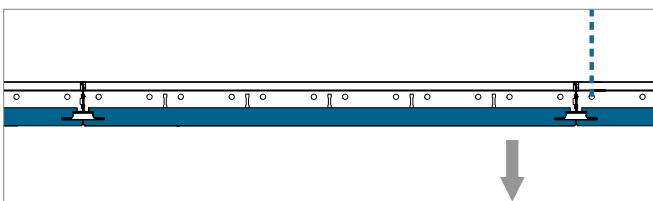

Drop the tile carefully into position.

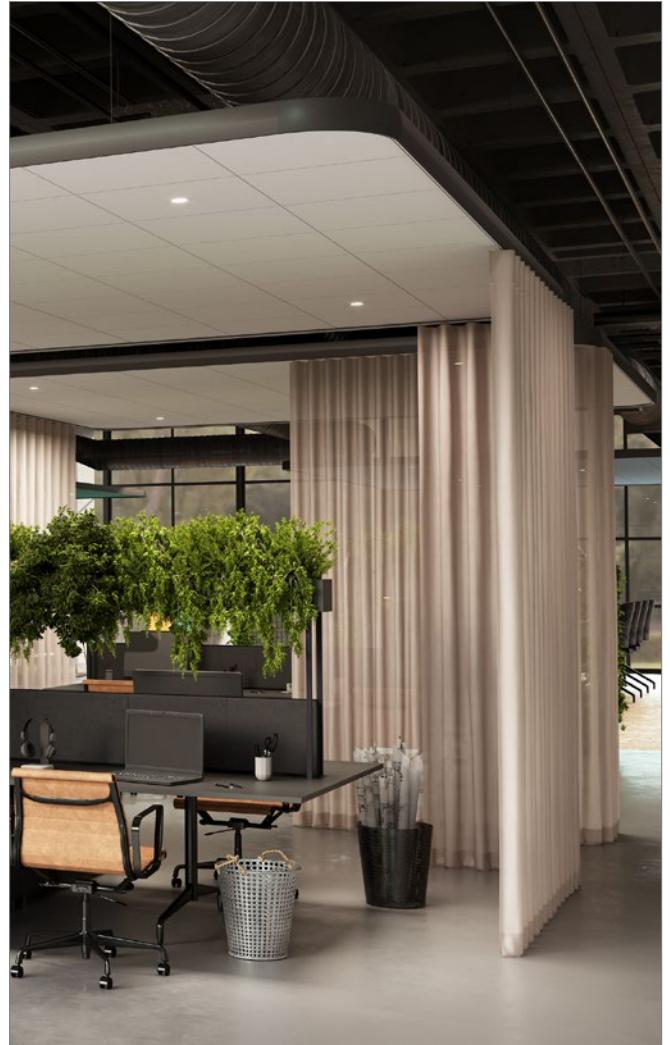

TIP



Use fresh white gloves to handle the tiles in order to avoid fingermarks.

Felt installation

Felt installation

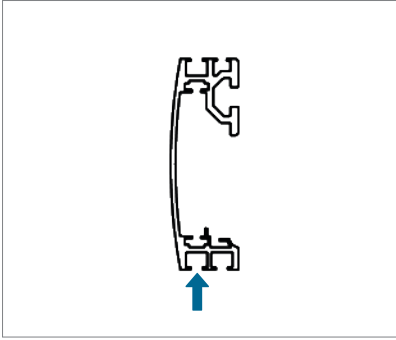

Slide the felt into the slot and pull it around the frame.

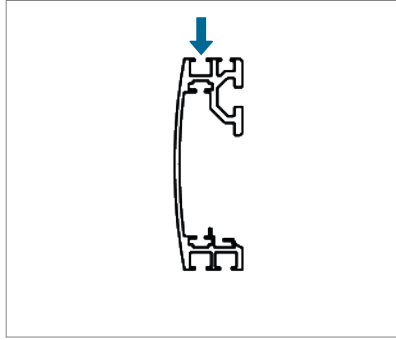

Flip the felt over and use the felt tool to push the felt in the top slot.

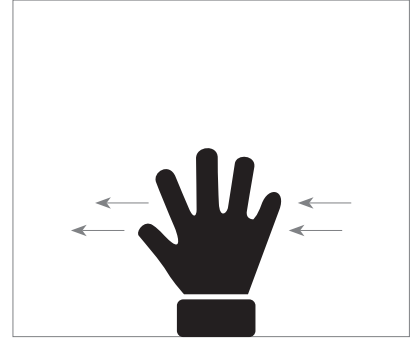

If applicable, use your hand to stroke out any creases in the felt.

Felt seem

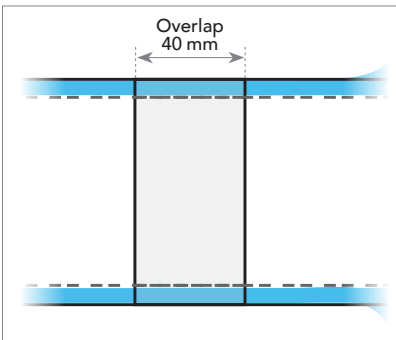

Before inserting the felt-ends in the frame (!), cut the felt with a 40 mm overlap. Leave extra wire on one end of the felt and cut it flush with the felt on the other.

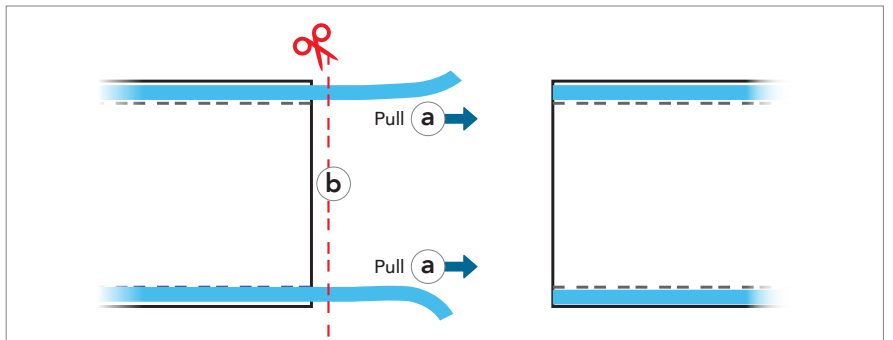

Pull the wires out (a) and cut (b) them so they jump back inside the felt.

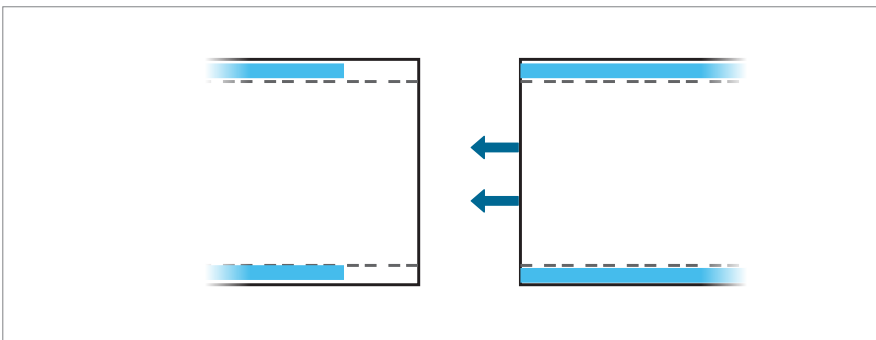

Pull the straight-cut felt over the felt with the retracted wires and push the wires in the slots.

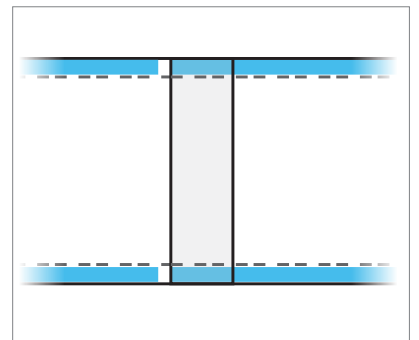

The seem should look as following. Now stroke out the last creases in the felt.

Service integration

Rockfon ceiling tiles are easy to cut and therefore, it is very easy to integrate service installations in our ceiling tiles. The cut-outs can be made with a simple utility knife.

When the system is installed to bear load, Rockfon recommends using a yoke or extra support arms that spread the weight of the service installation. Please be aware that, when installing a yoke or

support arms, the panel of Rockfon Hub is supported by the grid on only two sides. The size of the yoke should not be bigger than module 600 x 600 mm and the use of extra hangers to overcome deflection in the ceiling system is strongly recommended. When using support arms to spread the weight of the installation, Rockfon recommends spanning maximum 600 mm and the usage of extra hangers to overcome deflection in the ceiling system.

Planning

Rockfon recommends discussing the jobsite planning thoroughly and well in advance with other installers that have to work in or near Rockfon Hub. By doing so damaged tiles and dirty spots on the finished surface can be avoided, which reduces costs on the jobsite.

Overview load bearing capacity

| | Weight of installations | | |
|-----------------------------------------------------------------------------|-------------------------|-------------------|--------------------|
| | < 0,25 kg/pcs | 0,25 ≥ 3,0 kg/pcs | > 3,0 kg/pcs |
| Small service integration; Spot- or downlight, speaker, ventilation etc. | Drawing A | Drawing B | Suspend separately |
| Big service integration; Downlight, speaker, ventilation, etc. | Drawing A | Drawing B | Suspend separately |

When installing services in Rockfon Hub, you should always follow local building regulations if more strict than the load bearing capacity constraints Rockfon recommends in the above table.

Contact your local Rockfon technical service representative for more information on suitable downlights, accessories and availability of CAD drawings of the different services integrated in Rockfon Hub. Special solutions with integrated services are, if available, shown in the section 'Specific Solutions'.

Drawing A

The integration of a spotlight, smoke detector, speaker, etc. (weighing < 0,25 kg/pcs).

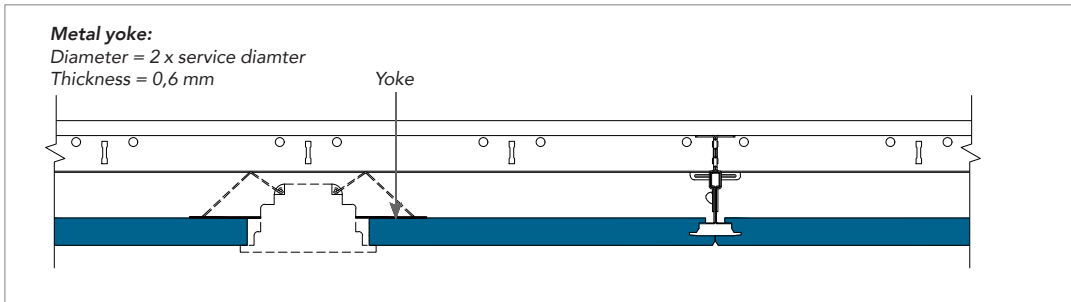

Drawing B

The integration of a down-, spotlight, smoke detector, loud speaker, etc. (weighing $0,25 \geq 3,0$ kg/pcs). Usage of a plywood yoke to spread the load on the back of the tile (as shown in the detail) or usage of support arms to spread the load to the grid system is strongly recommended. The use of extra hangers to avoid deflection is strongly recommended.

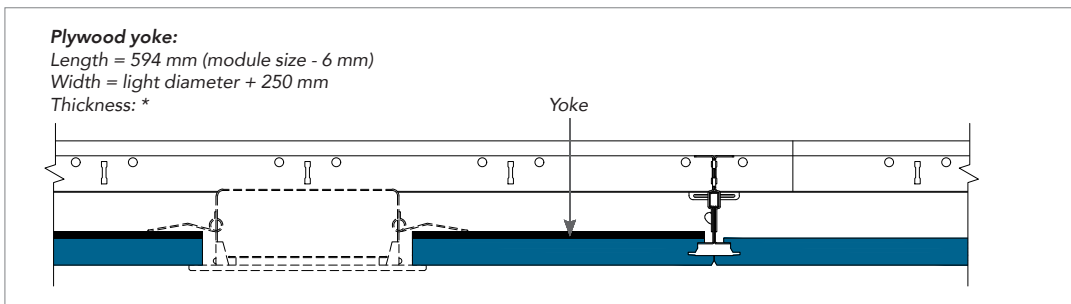

* The thickness of the plywood or metal yoke needs to be adapted in function of the weight, size and position of your service integration (e.g. downlight or speaker). The Plywood or metal yoke itself may not deflect after installing your service integration.

Specific Solutions

Bridging (Eliminate deflection)

Perfectly optimized for our Rockfon Systems, the bridging bracket feature gives the means to secure your T profiles across a variety of panel thicknesses ranging anywhere from 0 mm (only relevant for our Chicago Metallic™ T24 Click 2890 or Chicago Metallic T24 Click 2790) to 20 mm.

Easy to install, the bracket is a versatile, non-combustible tool and can be used for service integrations with different dimensions without the need of a using a yoke.

To install the bridging function of the bracket, simply screw fasten the Wall & bridging bracket for T profiles to your main runners and cross tees, transferring the weight of your service integration to the grid. This ensures that no load rests on the tile, eliminating concerns of deflection.

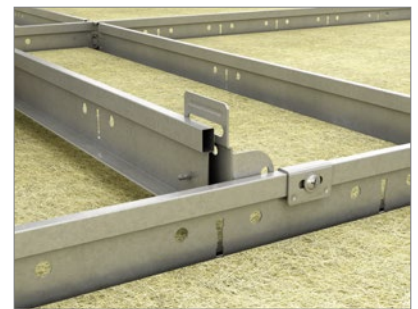
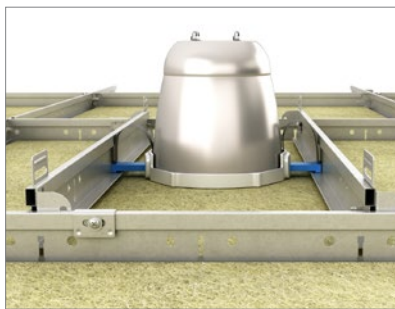

TIP



If bridging is required, order a Wall & Bridging bracket and Cross tee T24 Click 600 according to your needs.

General installation recommendations

Tiles

We recommend the use of clean nitrile or PU coated gloves when installing Rockfon tiles in order to avoid finger prints and pollution of the surface.

For an optimum work environment, we recommend installers always observe common work practices and follow the installation advice as shown on our packaging.

Cutting is made easy with a sharp knife. All offcuts and holes must be treated according to local Building Regulations.

Note! Certain smooth matte surfaces are directional. To ensure consistency of the finished surface, it is important that all tiles are installed in one direction, as indicated by the arrow printed on the back of each panel

Tools

Rockfon has developed specific tools that are available on cee.rockfon.international



Visit our online CAD Library or BIM portal to assist you in your project design.

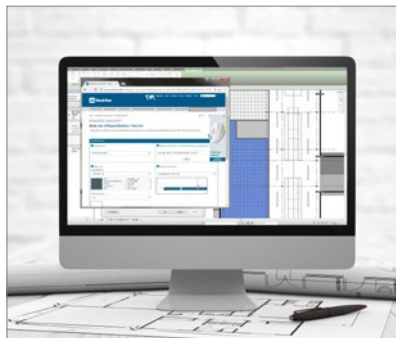

Generate specification texts for our products on our website.

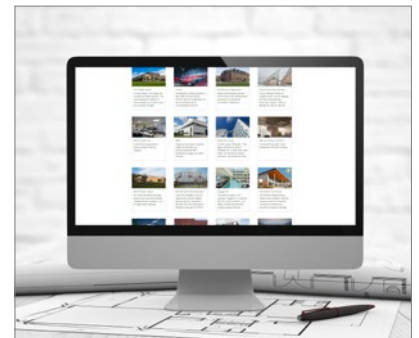

Explore our vast library of reference projects on our website.

Sounds Beautiful

